

## KL-0041-380 A / EA

Wheel Hub Extractor 12t

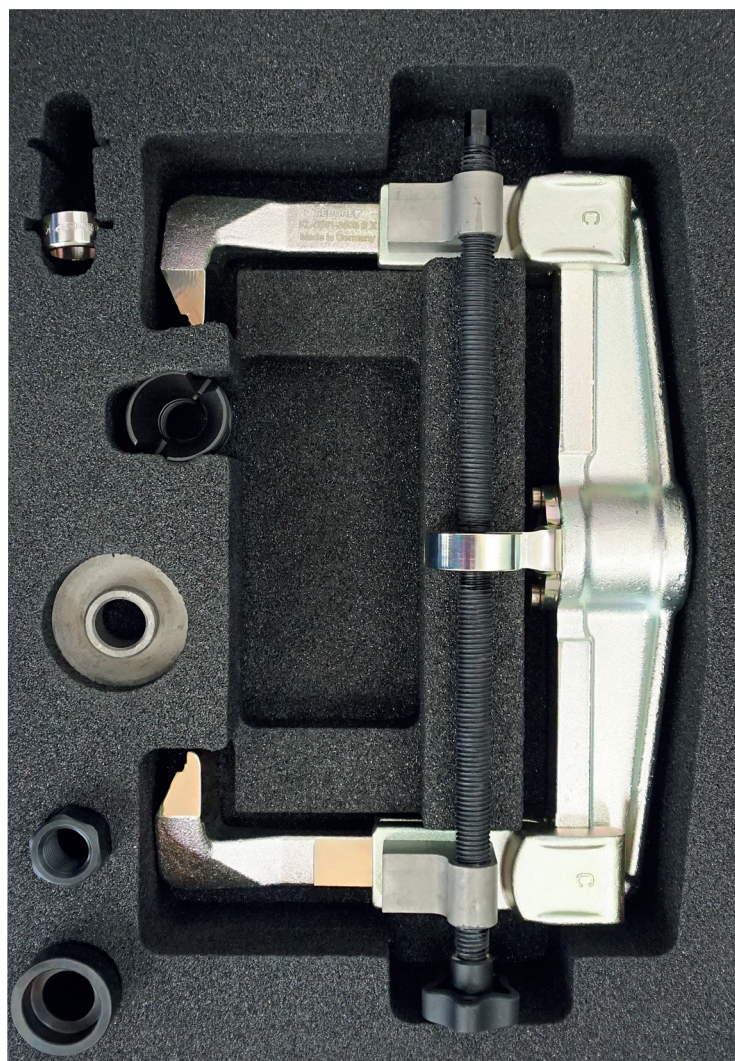

### GEDORE Automotive GmbH

Breslauer Straße 41  
78166 - Donaueschingen  
Postfach 1329  
78154 Donaueschingen - GERMANY  
☎ +49 (0) 771 / 8 32 23-0  
☎ +49 (0) 771 / 8 32 23-90  
✉ info.gam@gedore.com  
🌐 www.gedore-automotive.com



[www.gedore-automotive.com](http://www.gedore-automotive.com)



01/2024

KL-0041-380A (EN240107).indd

**ENGLISH****EN**

## Address of the manufacturer

**GEDORE Automotive GmbH**

Breslauer Straße 41 // 78166 Donaueschingen - GERMANY

☎ +49 (0)771/83223-71 // ✉ info.gam@gedore.com

## Imprint

In the course of improvement and adaptation to the state of the art, we reserve the right to make changes with regard to appearance, dimensions, weights and properties, and performance.

This does not imply any claim to correction or subsequent delivery of already delivered products. Deletions can be made at any time without any legal claim arising.

Instructions for use and safety are not binding. They never substitute for any legal or trade association regulations.

We do not accept any liability for printing errors.

Any reproduction, in whole or in part, requires the prior written consent of **GEDORE Automotive GmbH**.

All rights reserved worldwide.

© Copyright by **GEDORE Automotive GmbH** Donaueschingen (GERMANY)

We refer to our general terms and conditions, which can be found in the imprint at:

[www.gedore-automotive.com](http://www.gedore-automotive.com)



**CONTENTS**

**11. READ AND UNDERSTAND FOR YOUR SAFETY ..... 4**

1.1 Target group..... 4

1.2 Obligations of the owner..... 4

1.3 Intended use ..... 4

1.4 Reasonably foreseeable misuse ..... 4

1.5 Personal protective equipment..... 5

1.6 Labelling of the warnings..... 5

1.7 Work environment ..... 5

1.8 Emissions ..... 5

1.9 Basic safety instructions and warnings..... 6

1.10 Maintenance ..... 7

1.11 Troubleshooting..... 7

1.12 Care / Storage ..... 7

1.13 Repair ..... 7

1.14 Environmentally friendly disposal..... 7

**2. PRODUCT DESCRIPTION..... 8**

2.1 KL-0041-38.. A - Wheel hub extractor series ..... 8

2.2 Specifications..... 8

2.3 Wheel bearing overview ..... 9

2.4 Scope of delivery / spare parts overview ..... 10

**3. PREPARATION ..... 12**

3.1 Assembling drive parts ..... 12

3.2 Preparing the tool..... 13

3.3 Preparing the vehicle ..... 13

**4. EXAMPLE OF USE ..... 14**

4.1 Removal of a wheel bearing with a 1st generation compact wheel bearing ..... 14

4.2 Removing a 2nd generation compact wheel bearing..... 16

4.3 Removal of a screwed 3rd generation compact wheel bearing unit ..... 17

4.4 Removing a cardan shaft..... 19

## 1. READ AND UNDERSTAND FOR YOUR SAFETY



These operating instructions are intended to familiarise you with the operation of the wheel hub extractor. Therefore read and understand these operating instructions **before using** the wheel hub extractor and observe all safety and warning instructions for safe use! Misuse can result in **DEATH** or **SEVERE INJURIES**! The operating instructions are a part of the wheel hub extractor. Therefore keep them in a safe place so that you can access them at any time, and always pass them on to subsequent users of the wheel hub extractor! The wheel hub extractor complies with the recognised rules of technology as well as the relevant safety regulations!

### 1.1 Target group

These operating instructions are **exclusively** intended for skilled personnel in specialised motor vehicle workshops!

The wheel hub extractor **may only be** used by skilled personnel in specialised motor vehicle workshops who are familiar with the basic regulations on work safety and accident prevention!

▼ **Never** allow unauthorised, inexperienced persons, minors and children or persons with limited physical, sensory, and mental abilities to use the wheel hub extractor!

### 1.2 Obligations of the owner

Pursuant to the German Ordinance on Industrial Safety and Health (*BetrSichV*), employers are obliged to provide their employees with safe work equipment in accordance with the recognised rules of technology and the relevant safety regulations!

▼ The owner of the wheel hub extractor **must** ensure that **only** trained personnel in specialised vehicle workshops use the wheel hub extractor.

▼ The owner of the wheel hub extractor **must** ensure that the instructions for use are available to the user and that the user has completely read and understood the instructions for use **before** using the wheel hub extractor!

▼ The owner of the wheel hub extractor **must** ensure that the user is familiar with the basic regulations on work safety and accident prevention, and that the personal protective equipment is available, to him!

### 1.3 Intended use

The wheel hub extractor ...

▼ **may only be** used to pull out wheel bearings with 1st generation wheel hubs, 2nd generation compact wheel bearings, 3rd generation screwed wheel bearing units, as well as to pull out cardan shafts on passenger cars and commercial vehicles!

▼ **may only** be used to a **max. load of 12 tons!**

▼ **may only** be operated by hand with muscle power with a manual drive or a manually operated **GEDORE Automotive** hydraulic cylinder/pump combination with pressure gauge for safe pressure control!

▼ **may only** be used with **GEDORE Automotive** genuine spare parts and accessories!

▼ **may only** be used in the way described in these operating instructions!

▲ Any other use can result in **DEATH** or **SEVERE INJURIES!**

### 1.4 Reasonably foreseeable misuse

The wheel hub extractor ...

▼ **must never** be used for pulling out or pushing out other parts or in another way than intended!

▼ **must never** be used together with an impulse or impact screwdriver!

▼ **must never** be used with a machine-operated drive or a machine-operated hydraulic cylinder/pump combination!

▼ **must never** be used with a drive other than that intended for it!

▼ **must never** be used for batch processing with many forcing in/out processes within a few minutes!

▼ **must never** be used with a bridged, modified, or removed safety device!

▼ **must never** be modified, converted, or used for other purposes without authorisation!

▲ **Always** use the wheel hub extractor on as intended. Any other use can result in **DEATH** or **SEVERE INJURIES!**



### 1.5 Personal protective equipment

For your safety, **always** wear personal protective equipment when using the wheel hub extractor. The wheel hub extractor can bring about mechanical hazards such as crushing, cutting, and shock injuries.



Always wear **EYE PROTECTION** (for example to DIN EN 166, OSHA 29 CFR 1910.133, ANSI Z87) when using the wheel hub extractor to protect yourself against flinging parts or particles!

When using the wheel hub extractor, flying parts or particles can cause **SEVERE INJURIES** to your **eyes!**



Always wear **PROTECTIVE GLOVES** (for example to DIN EN 388, OSHA 29 CFR 1910.138, ANSI 105) when using the wheel hub extractor to protect yourself against sharp edges and crushing between parts!

When working with the wheel hub extractor, sharp edges and crushing between parts can cause **SEVERE INJURIES** to your **hands!**



Always wear **SAFETY SHOES** (for example to DIN EN ISO 20345, OSHA 29 CFR 1910.136, ANSI Z41) when using the wheel hub extractor to protect yourself against dropping parts!

When working with the wheel hub extractor, dropping parts can cause **SEVERE INJURIES** to your **feet and toes!**

### 1.6 Labelling of the warnings

**Warnings** warn of potential **hazards**. **Always** observe these warnings to avoid **DEATH** or **INJURIES!**

For better differentiation, warnings in these operating instructions are classified as follows:	
Warning sign	Meaning
	<b>Indicates</b> a hazardous situation, which, if not avoided, could cause <b>DEATH</b> or <b>SERIOUS INJURIES</b> .
	<b>Indicates</b> a hazardous situation which, if not avoided, could cause <b>MODERATE</b> or <b>MINOR INJURIES</b> .
	<b>Indicates</b> a situation which, if not avoided, could cause damage to the tool or an object in its vicinity.
	<b>Note</b> on important information and useful tips.

### 1.7 Work environment

**Only** use the wheel hub extractor in a safe working environment and **do not** expose it to extreme humidity and moisture!

- When using the wheel hub extractor, the workplace **must** be clean and tidy.
- The workplace **must** be sufficiently large and illuminated.
- The workplace **must** be on a solid and non-skidding floor.
- The workplace **must** be safeguarded against access of unauthorised persons.
- The workplace **must** be at room temperature between -10°C and +40°C.

### 1.8 Emissions

Molybdenum disulphide paste and hydraulic oil can drip or run when using the wheel hub extractor and thus pose a hazard to the environment.

- Immediately** remove leaking hydraulic oil as well as excess molybdenum disulphide paste (using oil binding agents or a cleaning cloth, for example).
- In case of skin contact with hydraulic oil, clean the affected area **immediately** with degreasing soap and water.
- Dispose of pollutants such as hydraulic oil and molybdenum disulphide paste **always in an environmentally friendly** manner.
- Safety data sheets *in accordance with Regulation (EC) No. 1907/2006* for hydraulic oil (**Alsus Hyd HLP 32 32**) as well as for molybdenum- paste (**MOLYKOTE® G-N PLUS PASTE**) can be found on the manufacturer's site on the Internet (**World Wide Web**) or, if required, contact **GEDORE Automotive**.

## 1.9 Basic safety instructions and warnings

### **⚠ WARNING - Failure to observe this warning may result in an accident or death.**

When using the wheel hub extractor, **always** observe the following safety and warning instructions as well as measures to avoid **DEATH** or **SERIOUS INJURY** as well as property damage due to hazards, misuse, abuse and unsafe handling!

- ✔ Read and understand these operating instructions **before using** the wheel hub extractor, and observe all safety and warning instructions for **safe use**!
- ✔ **Always** work with the wheel hub extractor in accordance with the basic regulations on work safety, accident prevention and environmental protection!
- ✔ **Always** use the wheel hub extractor on as intended. **GEDORE Automotive** does not accept any liability or warranty or guarantee claims for injuries and damage resulting from improper use or disregard of the safety regulations.
- ✔ **Before each use**, check the wheel hub extractor **carefully** for damage, loose parts, or unauthorised modifications. **Never** use it, if you notice any such deficiencies! Professional inspection and repair may only be carried out by specially trained personnel from **GEDORE Automotive**
- ✔ **Only** use original spare parts and accessories from **GEDORE Automotive** for the wheel hub extractor!
- ✔ **Always** observe the vehicle-specific manufacturer's specifications when working with the wheel hub extractor tool!
- ✔ Secure the wheel extractor and in particular the hydraulic cylinder against falling down and flinging around, for example by holding it or by using the **GEDORE** safety retaining belt - **KL-0040-2590** or, alternatively, the retaining device **KL-0040-258 A**!
- ✔ **Never** use the wheel hub extractor on with an impulse or impact wrench or any other drive than intended! Drive it only by hand and with muscle power; **only** use a manual drive or a manually operated **GEDORE Automotive** hydraulic cylinder / pump combination with a pressure gauge for safe pressure control!
- ✔ **Never** use the wheel hub extractor for batch processing with many operations within a few minutes!
- ✔ **Never** use the wheel hub extractor when you are tired or under the influence of alcohol, drugs, or medication!
- ✔ **If necessary**, carry, lift, and position the severe parts of the wheel hub extractor with the help of a second specialist!
- ✔ **Before using** the wheel hub extractor, make sure that **no** unauthorised persons are in the immediate environment!
- ✔ **Always** observe the **max. loading capacity** when using the wheel hub extractor, and **never** exceed it!
- ✔ **Never** stand in axial extension of the wheel extractor when it is under load!
- ✔ Wear your personal protective equipment such as safety goggles, protective gloves, safety shoes during work!
- ✔ **Never** leave the wheel hub extractor on unattended in loaded condition on the wheel bearing!
- ✔ **Never** hit the wheel wheel hub extractor with a hammer or other objects and **never** clamp it in a vice!
- ✔ **Always** avoid dropping, hitting or knocking the wheel hub extractor, especially when it is under load! **Always** place it on a clean shelf or workbench to prevent it from down!
- ✔ Prior to each use, check the moving parts and the spindle of the wheel hub extractor for sufficient lubrication. If necessary, lubricate them **only** with molybdenum disulphide paste (for example **GEDORE Automotive - KL-0014-0030**)!
- ✔ Interrupt your work **immediately** if you are unsure about using the wheel hub extractor and contact **GEDORE Automotive**, **if necessary**!
- ✔ **For safety reasons**, ensure that a damaged wheel hub extractor is no longer used! Professional inspection and repair may only be carried out by specially trained personnel from **GEDORE Automotive GmbH**!

## 1.10 Maintenance

Perform maintenance on the wheel hub extractor tool **at regular intervals** and **only** when the tool is depressurised and/or de-energised! Poor and improper maintenance can damage the wheel hub extractor, thus causing **DEATH** or **SEVERE INJURIES!**

### **Prior to each use:**

- ✔ **Prior to each use**, check the wheel hub extractor **carefully** for damage, loose parts, or unauthorised modifications!
- ✔ Prior to **each use** of the wheel hub extractor, check the spindle for contamination and damage. If necessary, clean it, and subsequently lubricate it **only** with molybdenum disulphide paste! (for example, **GEDORE Automotive - KL-0014-0030**)

### **Recommended: Every 24 months:**

- ✔ Have the wheel hub extractor professionally checked **every 24 months** by authorised **GEDORE Automotive** specialists!

## 1.11 Troubleshooting

**Always** perform troubleshooting on the wheel hub extractor when it is depressurised/tension-free.

**Problem:** Spindle or clamping nut on the wheel hub extractor stiff.

**Reason:** Spindles soiled or insufficiently lubricated; wrong lubricant used.

**Remedy:** Clean the spindles, check them for damage, and lubricate **exclusively** with molybdenum disulphide paste. (for example, **GEDORE Automotive - KL-0014-0030**)

**Problem:** Hydraulic oil escapes from the hydraulic coupling between hydraulic cylinder and hand pump.

**Reason:** Hydraulic coupling contaminated or loose.

**Remedy:** Clean and retighten the hydraulic coupling. Top up lacking hydraulic oil (**HLP 32 or 46**) at the hand pump.

**Problem:** The hydraulic hand pump does not build up pressure or only very slowly.

**Reason:** The pressure release valve on the hand pump is open or hydraulic oil is missing.

**Remedy:** Close the pressure release valve on the hand pump completely and top up missing hydraulic oil (**HLP 32 or 46**) on the hydraulic hand pump, if necessary.

## 1.12 Care / Storage

### **ATTENTION**

Improper care and storage can damage the wheel hub extractor.

- ✔ Therefore, **never** immerse the wheel hub extractor in water, solvents, or other cleaning liquids.
- ✔ After use, clean all parts wheel extractor when with a dry and clean cleaning cloth.
- ✔ Store the wheel hub extractor and the operating instructions at a dry and clean place.

## 1.13 Repair

### **⚠ WARNING**

Improper repair of the wheel hub extractor can result in **DEATH** or **SEVERE INJURIES**.

- ✔ If damage, loose parts or unauthorised modifications have been found on the wheel hub extractor, it must no longer be used for safety reasons!
  - ✔ Repair may only be carried out by specially trained personnel from **GEDORE Automotive**!
  - ✔ **Only** use original spare parts and accessories from **GEDORE Automotive** for the wheel hub extractor!
- If necessary, contact us, the **GEDORE Automotive** for a professional inspection and repair of the wheel hub extractor.

## 1.14 Environmentally friendly disposal

Dispose of the wheel hub extractor and the packaging material in an environmentally compatible way in accordance with the legal requirements. If necessary, ask your local authorities about environmentally friendly disposal options.

## 2. PRODUCT DESCRIPTION

### 2.1 KL-0041-38.. A - Wheel Hub Extractor Series

#### KL-0041-380 A - Wheel hub extractor 12t

Universally suitable for 1st generation wheel bearings and wheel hubs as well as for compact wheel bearings of the 2nd generation on passenger cars and commercial vehicles.

The wheel hub extractor enables wheel bearings, wheel hubs as well as wheel bearing units with a diameter of up to 250mm to be pulled out of a wheel bearing housing quickly and easily directly on the vehicle.

For the construction, which can bear a load of up to 12 tonnes, it does not matter whether they are rusted, glued or fitted with a locking ring.

Also suitable for pushing out stuck cardan shafts.

① The installation can be done e.g. with the wheel bearing tools from the **KL-0039-..** or **KL-0041-...series**. (see **GEDORE Automotive catalogue**)

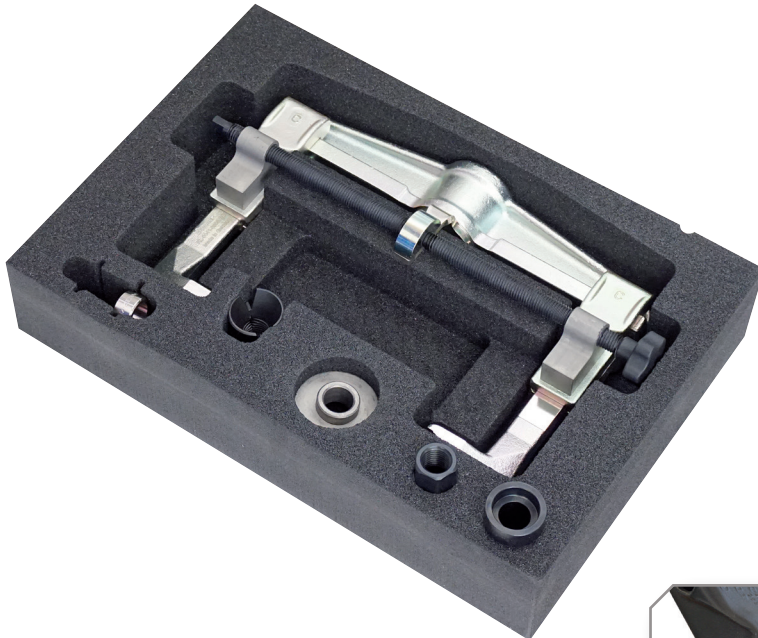

#### Required drive parts

**KL-0040-2500** - Hydraulic cylinder 17t

**KL-0215-35 M25** - Hand pump 17t

**KL-0039-1003** - Mounting adapter

**KL-0039-1920-1** - Pull spindle

#### Recommended accessories

**KL-0041-384** - Bead breaker kit

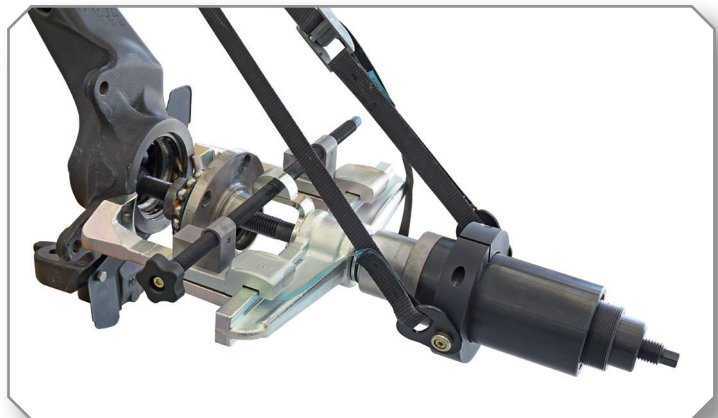

### 2.2 Specifications

Maximum load capacity\*: ..... 12 tonnes\*

\* in combination with thrust spindle (1.2606280KS): ..... 7 tonnes

Maximum span: ..... up to 250mm



**KL-0041-384 - Bead breaker kit**

Universally suitable for 3rd generation screwed wheel bearing units on passenger cars and commercial vehicles.

The special bead breakers, in conjunction with wheel hub extractor - KL-0041-3800 C, enable the simple and quick extraction of stuck wheel bearing units with a diameter of up to 250 mm from a wheel bearing housing directly on the vehicle.

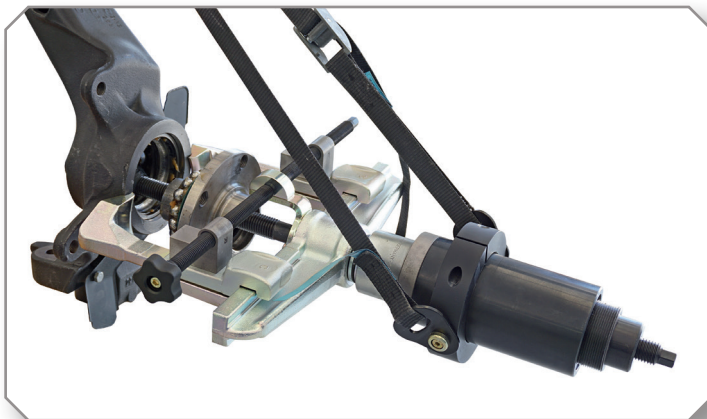

**Necessary accessories**

**KL-0041-3800 C** - Wheel hub extractor  
+ required drive parts

**2.3 Wheel bearing overview**

This overview shows examples of the basic differences between the individual wheel bearing generations.

**Wheel bearing with a 1st generation hub**

*Wheel bearing and hub individually*



**2nd generation compact wheel bearing**

*Wheel bearing and hub compactly connected*



**Screwed 3rd generation wheel bearing unit**

*Wheel bearing and hub individually or connected.*

*Wheel bearing is also a wheel bearing housing and thus a unit that is screwed to the steering knuckle.*



## 2.4 Scope of delivery / Overview of the single parts

① The table shows all components and individual parts of the **KL-0041-38.. A- Wheel hub extractor series**.

Prior to using the wheel hub extractor, check that all the parts included in the scope of delivery are available.

Base unit ...	Item	Wheel hub extractor kits		
		KL-0041-380 EA	KL-0041-380 A	KL-0041-384
KL-0214-2202 - Spacer ring Ø 30mm	<b>A</b>	●	●	
KL-0041-3800 C - Wheel hub extractor Base unit	<b>B..</b>	●	●	
KL-0041-3801 A - Bridge	<b>B1</b>	●	●	
KL-0041-3805 C - Clamping shoe pair (right-handed thread)	<b>B2</b>	●	●	
KL-0041-3804 C - Clamping shoe pair (left-handed thread)	<b>B3</b>	●	●	
KL-0121-3003- Star handle M8	<b>B4</b>	●	●	
KL-0055-0012 - Cheese-head screw nut M6 x 25mm	<b>B5</b>	●	●	
KL-0041-3808 - Adjusting spindle	<b>B5</b>	●	●	
KL-0041-3803 C - Hooks	<b>B6</b>	● 2x	● 2x	
KL-0284-9007 - Cheese-head screw nut M6 x 14mm	<b>B7</b>	● 2x	● 2x	
KL-0041-3806 - Bracket	<b>B8</b>	●	●	
KL-0041-3807 A - Spindle housing	<b>B8</b>	●	●	
KL-0028-2008 - Countersunk screw M6 x 14mm	<b>B9</b>	● 2x	● 2x	
KL-0039-1506 - Thrust ring Ø 60mm	<b>G</b>	●	●	
KL-0041-3812 - Clamping nut, Ø 30mm	<b>D</b>	●	●	
KL-0039-2192 - Conical adapter	<b>E</b>	●	●	
KL-0039-2120-2 - Quick clamping nut M20	<b>F</b>	●	●	
<b>Supplements...</b>				
KL-0041-3841-1 - Bead breaker (Type 1)	<b>G1</b>			● 2x
KL-0041-3842-1 - Bead breaker (Type 2)	<b>G2</b>			● 2x
<b>Storage...</b>				
KL-4999-1315 - Foam insert	□	●	Accessories	
KL-4999-1391 - Plastic case	□	Accessories	Accessories	

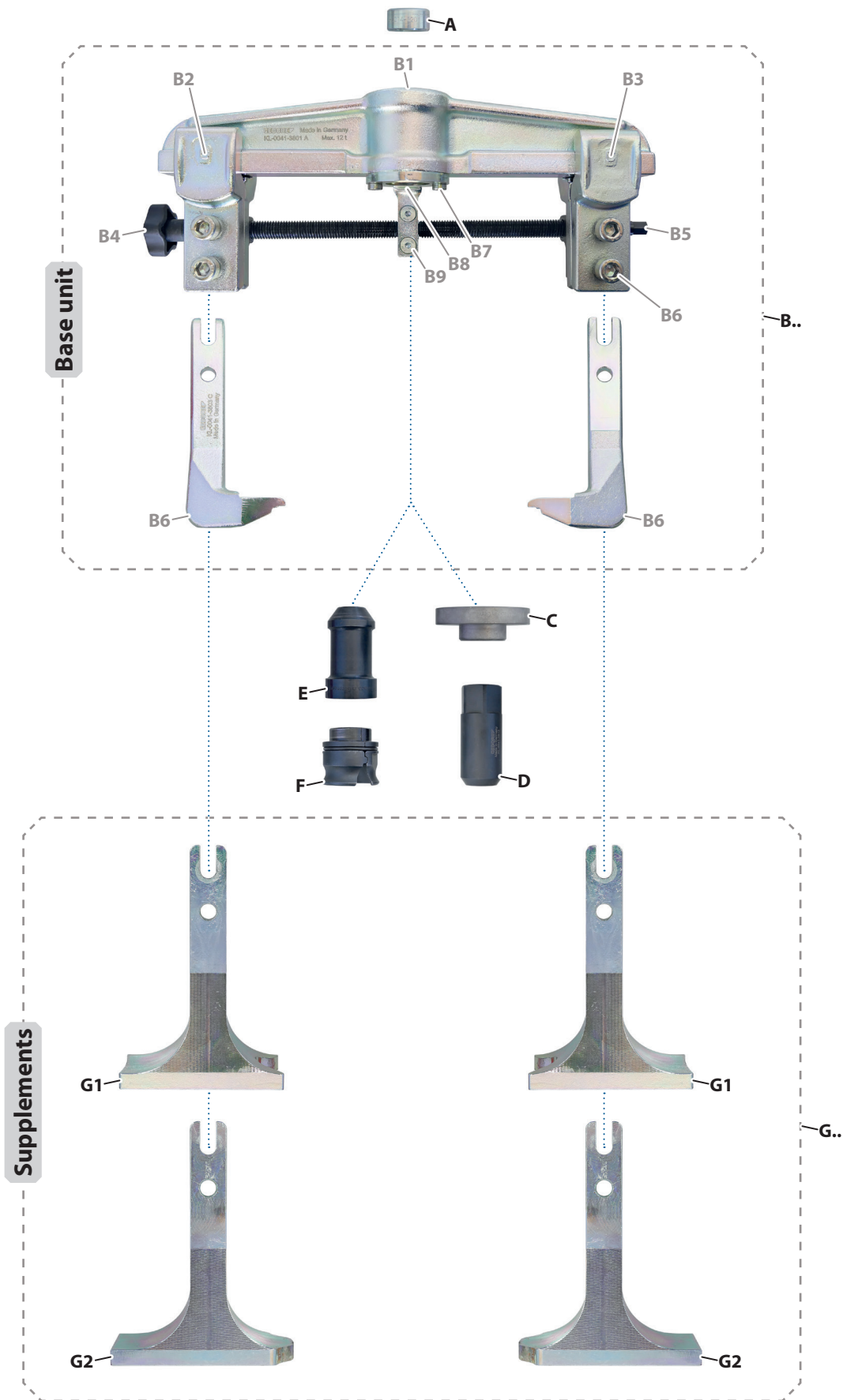

## 3. PREPARATION

### 3.1 Necessary drive parts

📷 1: Assemble the required drive parts...

#### ⚠️ WARNING

Using a machine-operated drive can cause the wheel hub extractor to slip, break, and thus drop or be hurled about. This can cause **DEATH** or **SEVERE INJURIES!**

- ▣ The wheel hub extractor must **never** be used with a mechanical drive, e.g. an impulse or impact wrench or a drive other than that intended for it!
- ▣ The wheel hub extractor **may only** be operated by hand with muscle power with a manual drive or a manually operated **GEDORE Automotive** hydraulic cylinder/pump combination with pressure gauge for safe pressure control!

1. Assemble the required drive parts for the wheel hub extractor as shown.

📖 For other drive components and accessories see the *GEDORE Automotive catalogue*.

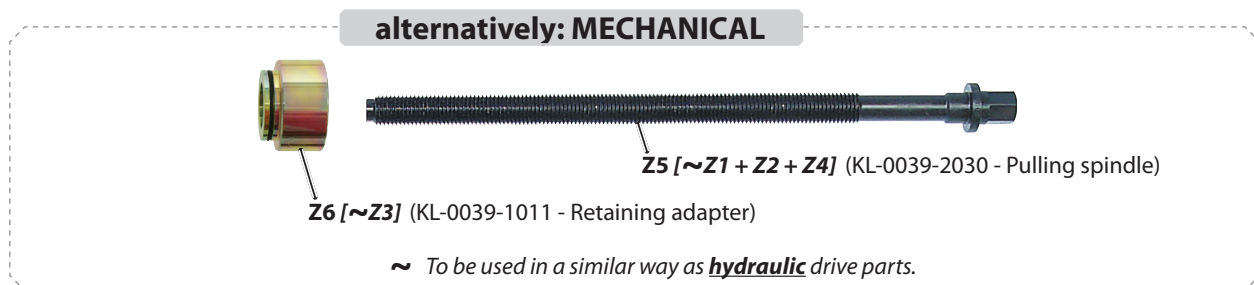
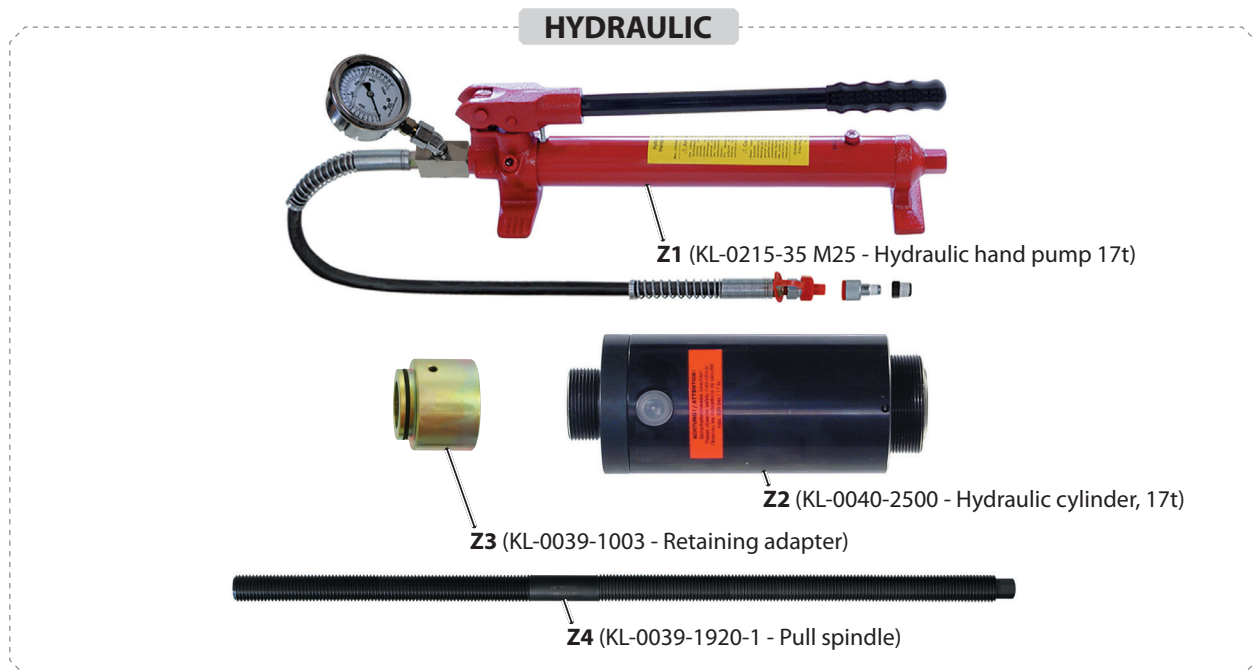



### 3.2 Preparing the tool

#### 📷 2: Preparing the tool

1. Assemble the wheel hub extractor depending on the type of drive (*hydraulic or mechanical*) as shown.

① The safety retaining belts - **KL-0040-2590** or **KL-0040-2592**, which are available as an *accessory*, or the mounting device - **KL-0040-258 A**, for example, make it possible to secure the wheel hub extractor against dropping.

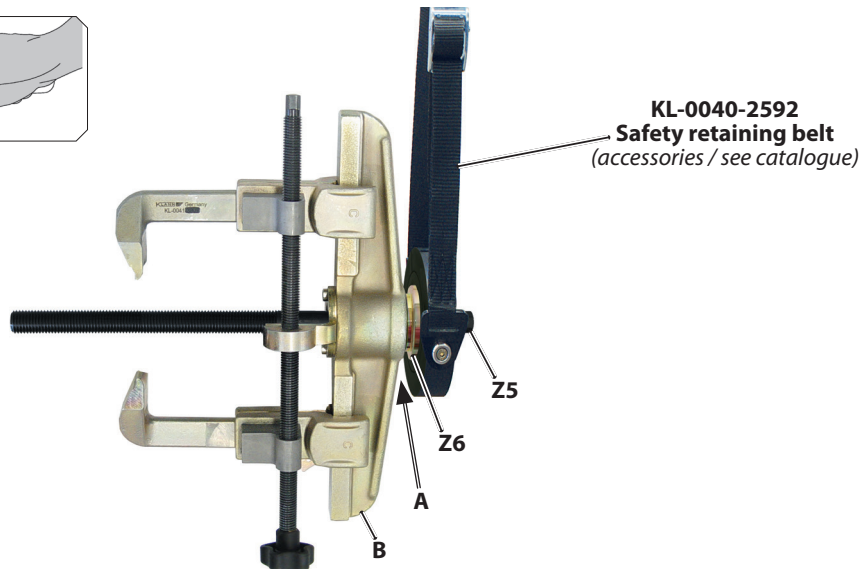
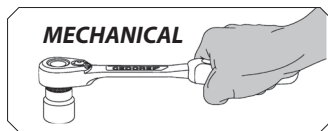
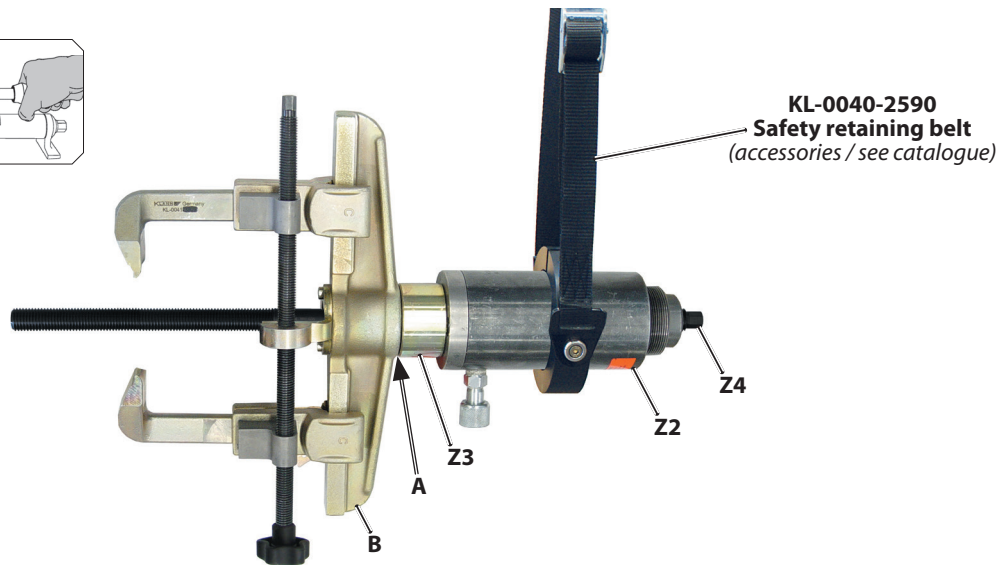
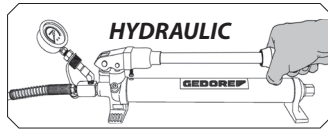

### 3.3 Preparing the vehicle

Loosen or remove all necessary parts as specified by the manufacturer (for example, unscrew wheel, remove brake, loosen central nut on wheel bearing).

Go to ...

- ➔ **Chapter 4.1** - Removal of a wheel bearing with 1st generation wheel hub
- ➔ **Chapter 4.2** - Removing a 2nd generation compact wheel bearing
- ➔ **Chapter 4.3** - Removal of a screwed 3rd generation wheel bearing unit
- ➔ **Chapter 4.4** - Removing a cardan shaft

## 4. TYPICAL APPLICATIONS

### 4.1 Removal of a wheel bearing with a 1st generation wheel hub

This application example describes the **hydraulic** extraction of a wheel hub from the wheel bearing and the extraction of a wheel bearing from the wheel bearing housing. **Mechanical** extraction also basically follows the same principle.

#### 📷3: Position the wheel hub extractor correctly...

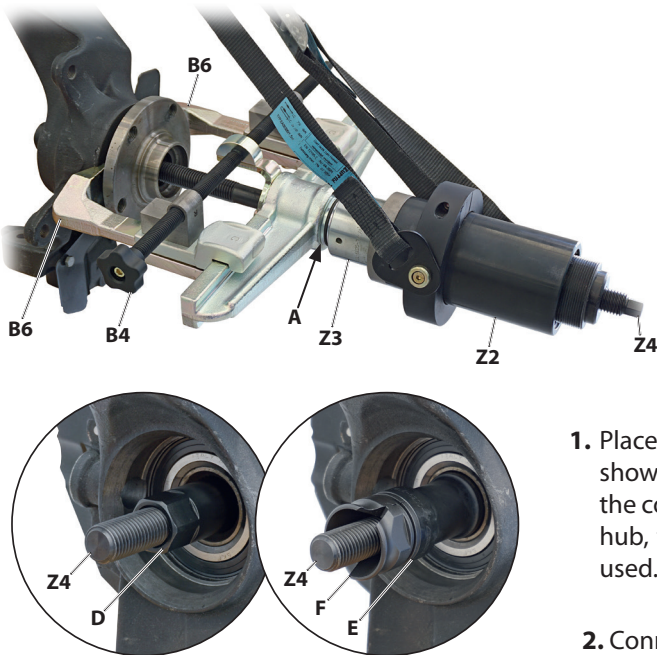

#### CAUTION

Risk of damaging the wheel hub extractor and the wheel hub bearing.

- ✔ The contact surfaces on the wheel bearing housing, on which the hooks [B6] are placed, **must be** level and at the same height so that the wheel hub extractor is exactly at right angles to the wheel hub!
- ✔ The hooks [B6] must be adjusted by turning the adjusting spindle via the star handle [B4] so that they rest evenly and without slipping on the wheel bearing housing over the largest possible area.

1. Place the wheel hub extractor on the wheel bearing housing as shown and screw the clamping nut [D] onto the pull spindle [Z4] in the correct position. Depending on the inner diameter of the wheel hub, the quick-clamping nut [F] with adapter [E] may have to be used.

2. Connect the hydraulic pump [Z1] with the hydraulic cylinder [Z2].

#### 📷4: Pulling out the wheel hub...

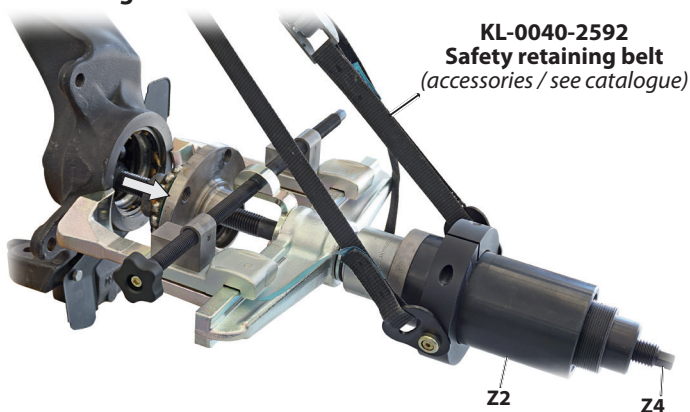

#### ⚠WARNING

The wheel hub extractor can break, fling around, and fall down when pulling out the wheel hub. This can cause **DEATH** or **SEVERE INJURIES**.

- ✔ **Never** exceed the **maximum load** of 12t!
- ✔ **Constantly** watch the pressure on the pressure gauge of the hydraulic pump [Z1] while pulling out.
- ✔ While pulling out, **never** stand in the axial extension of the pull spindle [Z4].
- ✔ Secure the wheel hub extractor against falling down, for example using the **GEDORE** safety belt - **KL-0040-2590!**

3. While you are operating the hydraulic pump [Z1], watch the pressure on the pressure gauge, and remove the wheel hub from the wheel bearing.

- ⓘ The maximum stroke of the hydraulic cylinder [Z2] is 45 mm! As soon as it is reached: Interrupt the forcing process, relieve the pressure at the hydraulic pump [Z1], re-tighten clamping nut [D] or [F] until it is fully applied, and continue the forcing process.

4. Relieve the hydraulic cylinder [Z2] via the hydraulic pump [Z1] and remove the wheel hub extractor from the wheel bearing housing.

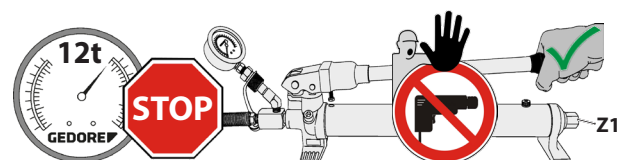

**5: Position the wheel hub extractor correctly...**

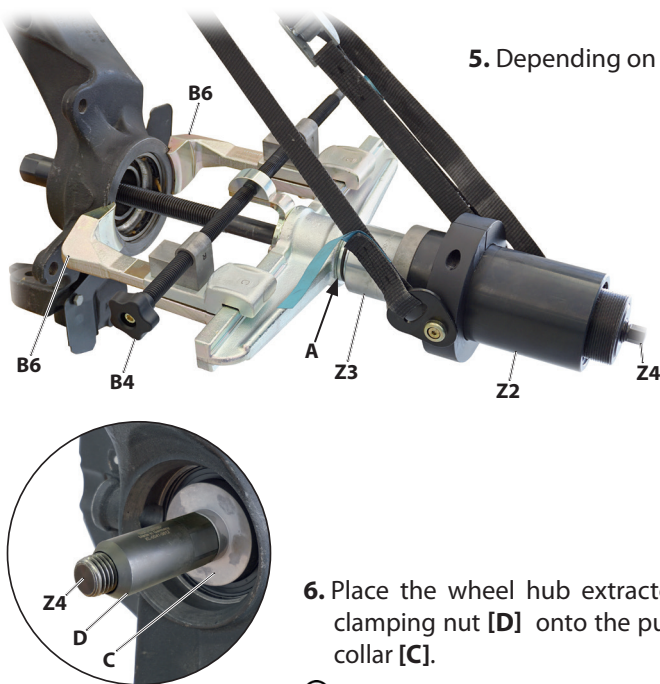

5. Depending on the vehicle, remove any wheel bearing circlip.

**CAUTION**

The wheel hub extractor, the thrust ring [C], and the wheel bearing housing can be damaged.

- ▼ The contact surfaces on the wheel bearing housing, on which the hooks [B6] are placed, **must be** level and at the same height so that the wheel hub extractor is exactly at right angles to the wheel!
- ▼ The hooks [B6] must be adjusted by turning the adjusting spindle via the star handle [B4] so that they rest evenly and without slipping on the wheel bearing housing over the largest possible area.

6. Place the wheel hub extractor on the wheel bearing housing as shown and screw the clamping nut [D] onto the pull spindle [Z4] in the correct position together with the thrust collar [C].

ⓘ The inner diameter at the wheel bearing must not be larger than **56mm**, otherwise the thrust ring [C] can be pulled into the wheel bearing. If necessary, use a larger thrust ring from the **GEDORE-Automotive KL-0039-...series**.

**6: Pulling out the wheel bearing...**

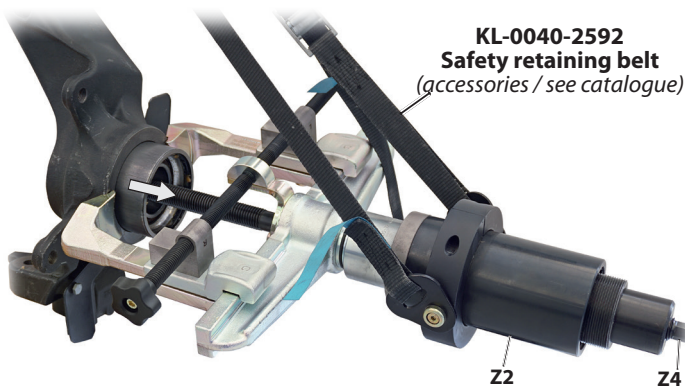

KL-0040-2592  
Safety retaining belt  
(accessories / see catalogue)

**! WARNING**

The wheel hub extractor can break, fling around, and fall down when pulling out the wheel bearing. This can cause **DEATH** or **SEVERE INJURIES!**

- ▼ **Never** exceed the **maximum load** of 12t!
- ▼ **Constantly** watch the pressure on the pressure gauge of the hydraulic pump [Z1] while pulling out.
- ▼ While pulling out, **never** stand in the axial extension of the pull spindle [Z4].
- ▼ Secure the wheel hub extractor against falling down, for example using the **GEDORE** safety belt - **KL-0040-2590!**

7. While you are operating the hydraulic pump [Z1], watch the pressure on the pressure gauge, and remove the wheel bearing from the wheel bearing housing.

ⓘ Make sure that the thrust ring [C] is centred on the wheel bearing.

ⓘ The maximum stroke of the hydraulic cylinder [Z2] is 45mm! As soon as it is reached: Interrupt the forcing process, relieve the pressure at the hydraulic pump [Z1], re-tighten the clamping nut [D] until it is fully applied, and then insert the forcing process.

8. Perform further work on the vehicle as specified by the manufacturer.

The subsequent installation can be carried out, for example, using the wheel bearing tools from the **KL-0039-...series**. (see *GEDORE Automotive catalogue*).

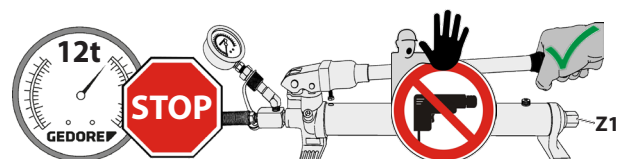



## 4.2 Removing a 2nd Generation compact wheel bearing

This typical application describes the **hydraulic** extraction of a compact wheel bearing from the wheel bearing housing. **Mechanical** extraction also basically follows the same principle.

### 📷7: Position the wheel hub extractor correctly...

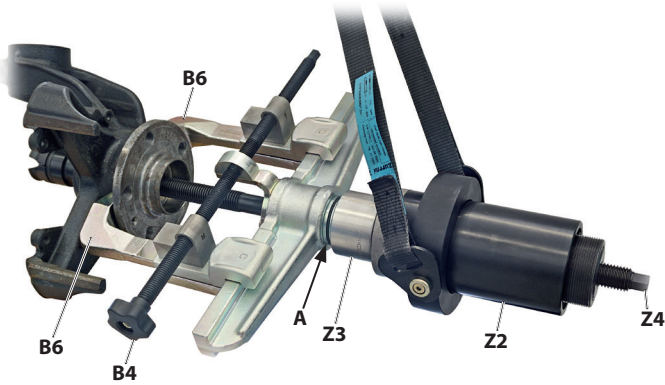

#### CAUTION

Risk of damaging the wheel hub extractor and the wheel hub bearing.

- ▼ The contact surfaces on the wheel compact housing, on which the hooks [B6] are placed, **must be** level and at the same height so that the wheel hub extractor is exactly at right angles to the compact wheel bearing!
- ▼ The hooks [B6] must be adjusted by turning the adjusting spindle via the star handle [B4] so that they rest evenly and without slipping on the wheel bearing housing over the largest possible area.

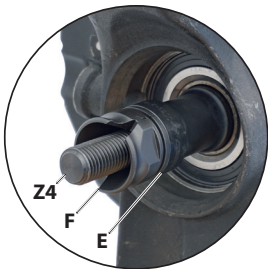

1. Place the wheel hub extractor on the wheel bearing housing as shown and screw the quick-clamping nut [F] onto the pull spindle [Z4] in the correct position together with the adapter [E].

2. Connect the hydraulic pump [Z1] with the hydraulic cylinder [Z2].

### 📷8: Pulling out the compact wheel bearing...

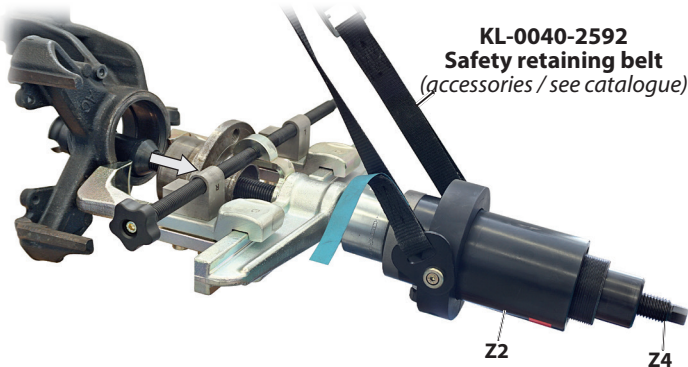

KL-0040-2592  
 Safety retaining belt  
 (accessories / see catalogue)

#### ⚠️WARNING

The wheel hub extractor can break, fling around, and fall down when pulling out the compact wheel bearing. This can cause **DEATH** or **SEVERE INJURIES!**

- ▼ **Never** exceed the **maximum load** of 12t!
- ▼ **Constantly** watch the pressure on the pressure gauge of the hydraulic pump [Z1] while pulling out.
- ▼ While pulling out, **never** stand in the axial extension of the pull spindle [Z4].
- ▼ Secure the wheel hub extractor against falling down, for example using the **GEDORE** safety belt - **KL-0040-2590!**

- ① The maximum stroke of the hydraulic cylinder [Z2] is 45 mm! As soon as it is reached: Interrupt the forcing process, relieve the pressure at the hydraulic pump [Z1], re-tighten the quick-clamping nut [F] until it is fully applied, and continue the forcing process.

4. Relieve the hydraulic cylinder [Z2] via the hydraulic pump [Z1] and remove the wheel hub extractor from the wheel bearing housing. Perform further work on the vehicle as specified by the manufacturer.

The subsequent installation can be carried out, for example, using the wheel bearing tools from the **KL-0041-4-..series**. (see *GEDORE Automotive catalogue*).

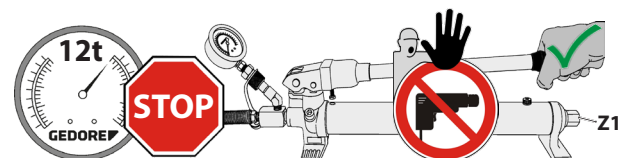



### 4.3 Removal of a screwed 3rd generation wheel bearing unit

This application example describes the **hydraulic** extraction of a wheel hub from the wheel bearing unit and the extraction of a screwed wheel bearing unit from the wheel bearing housing. **Mechanical** extraction also basically follows the same principle.

**📷9: Position the wheel hub extractor correctly...**

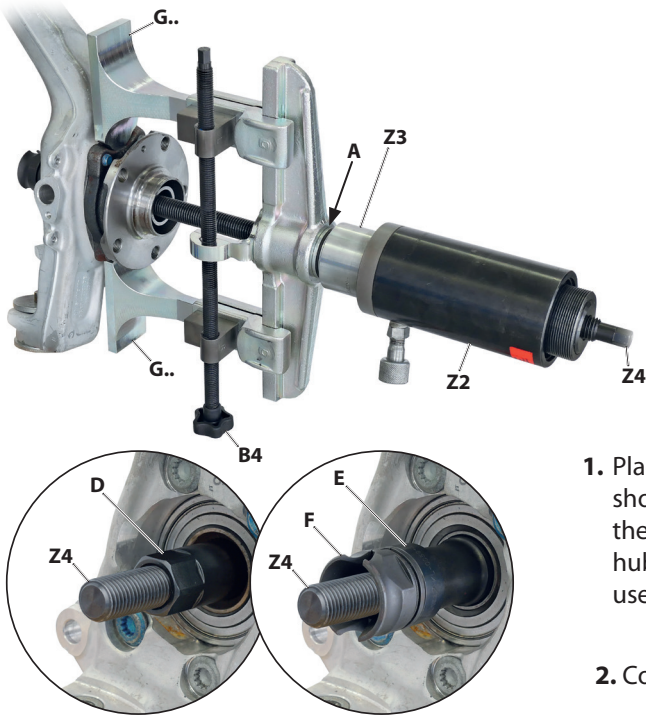

#### CAUTION

Risk of damaging the wheel hub extractor and the wheel hub bearing.

- ▼ The contact surfaces on the wheel bearing housing, on which the bead breakers [G..] are placed, **must be level** and at the same height so that the wheel hub extractor is exactly at right angles to the wheel hub!
- ▼ The bead breakers [G..] must be adjusted by turning the adjustment spindle via the star handle [B4] so that they rest evenly and without slipping on the wheel bearing housing over the largest possible area.

1. Place the wheel hub extractor on the wheel bearing housing as shown and screw the clamping nut [D] onto the pull spindle [Z4] in the correct position. Depending on the inner diameter of the wheel hub, the quick-clamping nut [F] with adapter [E] **may** have to be used.

2. Connect the hydraulic pump [Z1] with the hydraulic cylinder [Z2].

**📷10: Pulling out the wheel hub...**

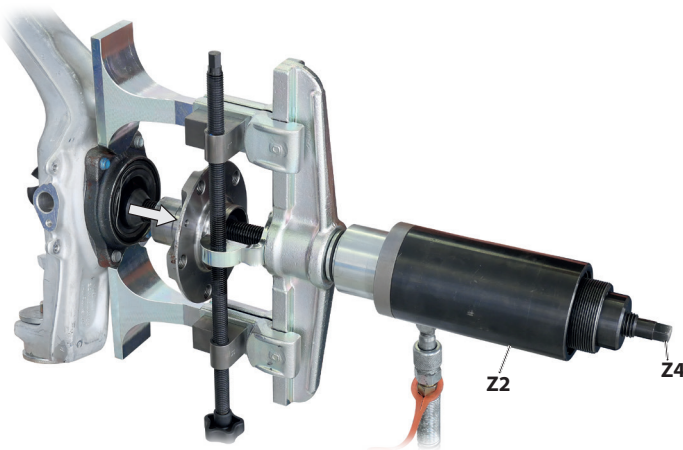

#### ⚠️WARNING

The wheel hub extractor can break, fling around, and fall down when pulling out the wheel hub. This can cause **DEATH** or **SEVERE INJURIES**.

- ▼ **Never** exceed the **maximum load of 12t!**
- ▼ **Constantly** watch the pressure on the pressure gauge of the hydraulic pump [Z1] while pulling out.
- ▼ While pulling out, **never** stand in the axial extension of the pull spindle [Z4].
- ▼ Secure the wheel hub extractor against falling down, for example using the **GEDORE** safety belt - **KL-0040-2590!**

3. While you are operating the hydraulic pump [Z1], watch the pressure on the pressure gauge and remove the wheel hub from on the wheel bearing unit.

ⓘ The maximum stroke of the hydraulic cylinder [Z2] is 45mm! As soon as it is reached: Interrupt the forcing process, relieve the pressure at the hydraulic pump [Z1], re-tighten clamping nut [D] or [F] until it is fully applied, and continue the forcing process.

4. Relieve the hydraulic cylinder [Z2] via the hydraulic pump [Z1] and remove the wheel hub extractor from the wheel bearing housing.

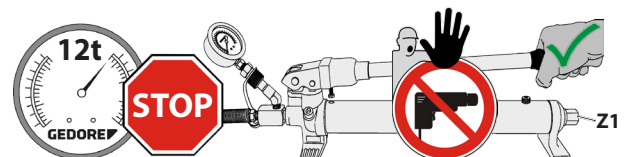

## 11: Position the wheel hub extractor correctly...

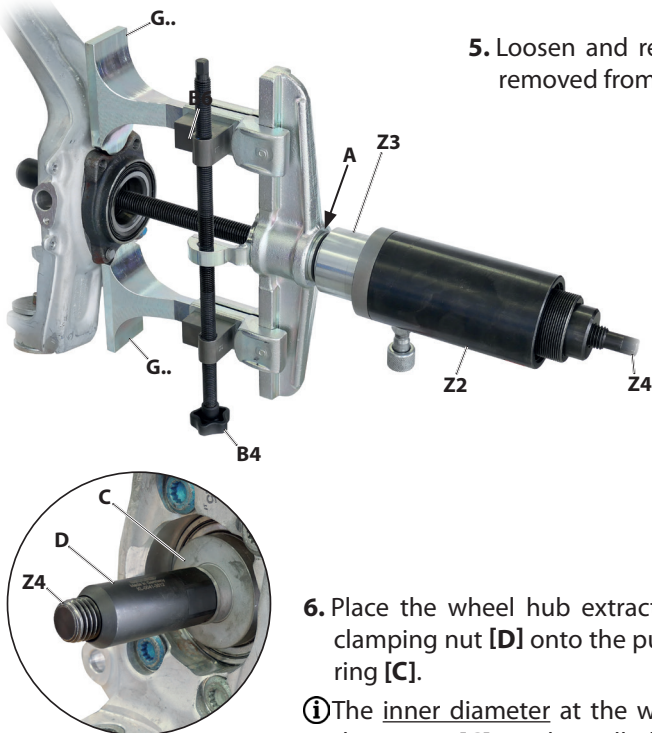

5. Loosen and remove the screws of the wheel bearing unit. If it cannot be removed from the wheel bearing housing, continue with the next step.

### CAUTION

The wheel hub extractor, the thrust ring [C], and the wheel bearing housing can be damaged.

- ▼ The contact surfaces on the wheel bearing housing, on which the bead breakers [G..] are placed, **must be** level and at the same height so that the wheel hub extractor is exactly at right angles to the wheel bearing unit!
- ▼ The bead breakers [G..] must be adjusted by turning the adjustment spindle via the star handle [B4] so that they rest evenly and without slipping on the wheel bearing housing over the largest possible area.

6. Place the wheel hub extractor on the wheel bearing housing as shown and screw the clamping nut [D] onto the pull spindle [Z4] in the correct position together with the thrust ring [C].

- ⓘ The inner diameter at the wheel bearing must not be larger than **56mm**, otherwise the thrust ring [C] can be pulled into the wheel bearing. If necessary, use a larger thrust ring from the **GEDORE-Automotive KL-0039-..series**.

## 12: Pulling out the wheel bearing unit...

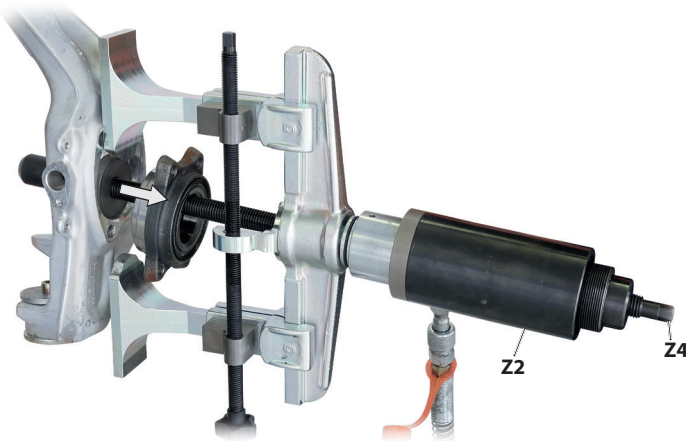

### ! WARNING

The wheel hub extractor can break, fling around, and fall down when pulling out the wheel bearing. This can cause **DEATH** or **SEVERE INJURIES!**

- ▼ **Never** exceed the **maximum load** of 12t!
- ▼ **Constantly** watch the pressure on the pressure gauge of the hydraulic pump [Z1] while pulling out.
- ▼ While pulling out, **never** stand in the axial extension of the pull spindle [Z4].
- ▼ Secure the wheel hub extractor against falling down, for example using the **GEDORE** safety belt - **KL-0040-2590!**

7. While you are operating the hydraulic pump [Z1], watch the pressure on the pressure gauge, and remove the wheel bearing unit from the wheel bearing housing.

- ⓘ Make sure that the thrust ring [C] is centred on the wheel bearing.

- ⓘ The maximum stroke of the hydraulic cylinder [Z2] is 45 mm! As soon as it is reached: Interrupt the forcing process, relieve the pressure at the hydraulic pump [Z1], re-tighten the clamping nut [D] until it is fully applied, and the insertion the forcing process.

8. Perform further work on the vehicle as specified by the manufacturer.

The subsequent installation of the wheel hub can be carried out, for example, using the wheel bearing tools from the **KL-0039-..series**. (see *GEDORE Automotive catalogue*).

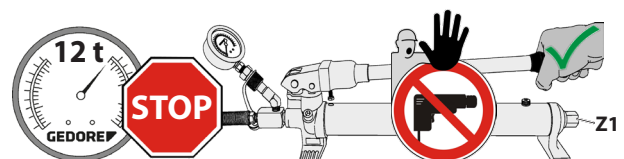

## 4.4 Removing a cardan shaft

This application example describes the **mechanical** pressing out of a glued or stuck cardan shaft from the wheel hub using the thrust spindle available from GEDORE - 1.2606280KS.

### 📷 13: Position the wheel hub extractor correctly...

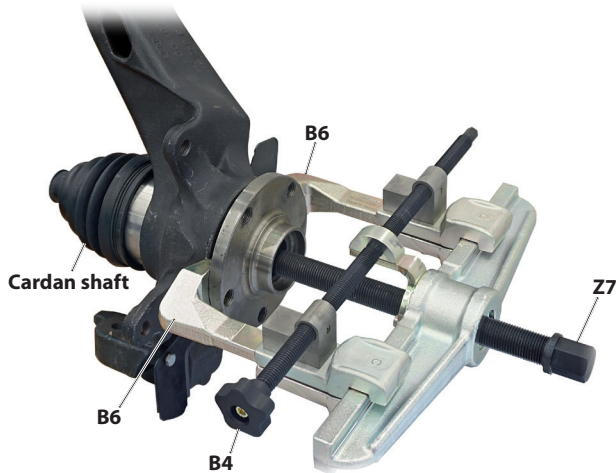

#### CAUTION

Risk of damaging the wheel hub extractor and the wheel hub.

- ✔ The contact surfaces on the rear of the wheel hub, on which the hooks [B6] are placed, **must be** level and at the same height so that the wheel hub extractor is exactly at right angles to the wheel hub!
- ✔ The hooks [B6] must be adjusted by turning the adjusting spindle via the star handle [B4] so that they rest evenly and without slipping on the wheel bearing housing over the largest possible area!
- ✔ When using the thrust spindle [Z7], the max. load capacity of the wheel hub extractor is reduced to **7t!**

1. Position the wheel hub extractor on the wheel hub as shown.

Then screw in the pressure spindle [Z7] until it rests against the cardan shaft or cardan shaft screw.

### 📷 14: Pressing out of the cardan shaft...



#### ⚠ WARNING

The wheel hub extractor can break, fling around, and fall down when pressing out the cardan shaft. This can cause **DEATH** or **SEVERE INJURIES!**

- ✔ **Never** exceed the **maximum load** of **7t!**
  - ✔ Secure the wheel hub extractor against falling down, for example by holding it!
2. Turn the pressure spindle [Z7] clockwise using a reversible ratchet (**size 27mm**) and push the cardan shaft out of the wheel hub.



Max. 7 tonnes

3. Perform further work on the vehicle as specified by the manufacturer.

## GEDORE Automotive GmbH

Breslauer Str. 41  
78166 Donaueschingen  
GERMANY  
Tel: +49 771 83 223 0  
Fax: +49 771 83 223 90  
[www.gedore-automotive.com](http://www.gedore-automotive.com)

## GEDORE International:

### GEDORE Torque Solutions GmbH

Bertha-Benz-Straße 12  
71665 Vaihingen/Enz  
GERMANY  
Tel: +49 70 42 94 41 0  
Fax: +49 70 42 9441 41  
[www.gedore-torque-solutions.com](http://www.gedore-torque-solutions.com)

### GEDORE France SARL

Parc d'activités des Béthunes – La Mare II 10, avenue du Fief – Bâtiment 12  
BP 79144 - Saint-Ouen-L'Aumône / 95074 CERGY PONTOISE CEDEX  
FRANCE  
Tél: +33 1 34 40 16 60  
Fax: +33 1 34 40 16 61  
[www.gedore.fr](http://www.gedore.fr)

### GEDORE Polska Sp. z.o.o.

Żwirki i Wigury 56, Mikołów  
POLAND  
Tel: +48 32 738 40-10  
Fax: +48 32 738 40-20  
[www.gedore.pl](http://www.gedore.pl)

### GEDORE India Pvt. Ltd.

Plot No. 148, Sector-3, IMT Manesar  
Gurugram, Haryana-122051  
INDIA  
Tel: +91 124 4087979  
[sales@gedoreindia.com](mailto:sales@gedoreindia.com)  
[www.gedore.in](http://www.gedore.in)

### GEDORE Tools South Africa (PTY) Ltd.

103 Qashana Khuzwayo Road, Durban / Kwazulu-Natal  
New Germany, 3610  
SOUTH AFRICA  
Tel: +27 3 17 05 35 87  
Fax: +27 3 17 05 47 35  
[www.gedore.co.za](http://www.gedore.co.za)

### GEDORE Tool Trading Co., Ltd. Shanghai, China

1/F, Block 2, 1358 Pingan Road  
Minhang, Shanghai, China 201109  
CHINA  
Tel: +86 21 33 88 72-58  
Fax: +86 21 33 88 72-59  
[www.gedore.cn](http://www.gedore.cn)

### GEDORE Ibèrica S.L., Spain

c/Arangutxi 12, Poligono Industrial de Júndiz  
01015 Vitoria Alava  
SPAIN  
Tel: +34 945 292 262  
Fax: +34 945 292 199  
[www.gedore.es](http://www.gedore.es)

## GEDORE Headquarter:

### GEDORE Werkzeugfabrik GmbH & Co. KG

Remscheider Str. 149  
42899 Remscheid  
GERMANY  
Tel: +49 2191 596 900  
Fax: +49 2191 596 999  
[www.gedore.com](http://www.gedore.com)

### GEDORE AUSTRIA GmbH

Gedore-Straße 1  
8190 Birkfeld  
AUSTRIA  
Tel: +43 3174 3636 0  
Fax: +43 31 74 36 38 320  
[www.gedore.at](http://www.gedore.at)

### GEDORE Torque UK Ltd.

Tannery Ln, Gosden Common  
Guildford GU5 0AJ  
UK  
Tel: +44 14 83 89 27 72  
Fax: +44 14 83 89 85 36  
[www.gedore-torque.com](http://www.gedore-torque.com)

### GEDORE Technag BV, Netherlands

Flemingweg 7  
2408 AV Alphen aan Den Rijn  
NETHERLANDS  
Tel: +31 1 72 42 73 50  
Fax: +31 1 72 42 73 60  
[www.gedore.nl](http://www.gedore.nl)

### Ferramentas GEDORE do Brasil S.A.

Rua Vicentina Maria Fidélis, 275 Bairro Vicentina  
São Leopoldo - RS - CEP: 93025-340  
BRASIL  
Tel: +51 35 89 92 00  
Fax: +51 35 89 92 22  
[www.gedore.com.br](http://www.gedore.com.br)

### GEDORE UK Ltd.

Marston St, Skipton  
North Yorkshire BD23 1TF  
UNITED KINGDOM  
Tel: +44 17 56 70 67 00  
Fax: +44 17 56 79 80 83  
[www.gedoreuk.com](http://www.gedoreuk.com)

### GEDORE Torque Ltd., UK

Bramley  
Guildford, Surrey, GU5 0AJ  
UNITED KINGDOM  
Tel: +44 1483 894476  
[www.gedore-torque.com](http://www.gedore-torque.com)

### GEDORE Tools Inc. USA

4055 Faber PI Dr  
North Charleston, SC 29405  
USA  
Tel: +1 843 225 5015  
[www.gedoretools.com](http://www.gedoretools.com)