



## KL-0041-452 C

### Wheel Bearing Tool, Ø 85mm



**Operating instructions** EN  
 ⚠ Read and understand before use!

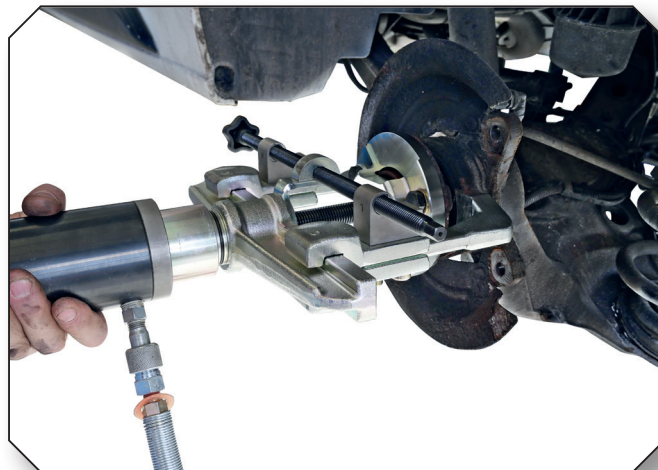

[www.gedore-automotive.com](http://www.gedore-automotive.com)



**GEDORE Automotive GmbH**

Breslauer Straße 41  
 78166 - Donaueschingen  
 Postfach 1329  
 78154 Donaueschingen - GERMANY

☎ +49 (0) 771 / 8 32 23-0  
 ☎ +49 (0) 771 / 8 32 23-90  
 ✉ info.gam@gedore.com  
 🌐 gedore-automotive.com

**GEDORE TOOLS, INC.**

Only for USA, Canada & Mexico / Sólo para EE.UU., Canadá y México  
 Seulement pour les USA, le Canada et le Mexique  
 7187 Bryhawke Circle, Suite 700  
 North Charleston, SC 29418, USA

☎ +1-843 / 225 50 15  
 ☎ +1-843 / 225 50 20  
 ✉ info@gedoretools.com  
 🌐 gedore.com

Version 04/2023

KL-0041-452C (EN)230409.indd



**ENGLISH**

**EN**

EN

## Address of the manufacturer

**GEDORE Automotive GmbH**

Breslauer Straße 41 // 78166 Donaueschingen - GERMANY

+49 (0)771/83223-71 // [info.gam@gedore.com](mailto:info.gam@gedore.com)

## Imprint

In the course of improvement and adaptation to the state of the art, we reserve the right to make changes with regard to appearance, dimensions, weights and properties, and performance.

This does not imply any claim to correction or subsequent delivery of already delivered products. Deletions can be made at any time without any legal claim arising.

Instructions for use and safety are not binding. They never substitute for any legal or trade association regulations.

We do not accept any liability for printing errors.

Any reproduction, in whole or in part, requires the prior written consent of **GEDORE Automotive GmbH**.

All rights reserved worldwide.

© Copyright by **GEDORE Automotive GmbH** Donaueschingen (GERMANY)

We refer to our general terms and conditions, which can be found in the imprint at:

[www.gedore-automotive.com](http://www.gedore-automotive.com)



# CONTENTS

<b>1. READ AND UNDERSTAND FOR YOUR SAFETY .....</b>	<b>4</b>
1.1 Target group.....	4
1.2 Obligations of the owner.....	4
1.3 Intended use .....	4
1.4 Reasonably foreseeable misuse .....	4
1.5 Personal protective equipment.....	5
1.6 Labelling of the warnings.....	5
1.7 Work environment .....	5
1.8 Emissions .....	5
1.9 Basic safety instructions and warnings.....	6
1.10 Maintenance .....	7
1.11 Troubleshooting.....	7
1.12 Care / Storage .....	7
1.13 Repair .....	7
1.14 Environmentally friendly disposal.....	7
<b>2. PRODUCT DESCRIPTION.....</b>	<b>8</b>
2.1 KL-0041-452 C - Wheel bearing tool, Ø 85mm.....	8
2.2 Scope of delivery / spare parts overview .....	8
2.3 Specifications.....	8
<b>3. PREPARATION .....</b>	<b>9</b>
3.1 Required drive parts .....	9
<b>4. EXAMPLE OF USE .....</b>	<b>10</b>
4.1 Removing wheel bearing unit .....	10
4.2 Pressing in wheel bearing unit .....	14

## 1. READ AND UNDERSTAND FOR YOUR SAFETY



Read and understand these operating instructions **before using** the wheel bearing tool, and observe all safety and warning instructions! Misuse can result in **DEATH** or **SEVERE INJURIES** ! These operating instructions are an integral part of the wheel bearing tool. Keep them at a safe place for future reference, and always pass them on to subsequent users of the wheel bearing tool! The wheel bearing tool complies with the recognised rules of technology as well as the relevant safety regulations!

### 1.1 Target group

These operating instructions are **exclusively** intended for skilled personnel in specialised motor vehicle workshops!

The wheel bearing tool **may only be** used by skilled personnel in specialised motor vehicle workshops who are familiar with the basic regulations on work safety and accident prevention!

▼ **Never** allow unauthorised, inexperienced persons, minors and children, or persons with limited physical, sensory, and mental abilities to use the wheel bearing tool!

### 1.2 Obligations of the owner

Pursuant to the German Ordinance on Industrial Safety and Health (*BetrSichV*), employers are obliged to provide their employees with safe work equipment in accordance with the recognised rules of technology and the relevant safety regulations!

▼ The owner of the wheel bearing tool **must** ensure that **only** trained personnel in specialised vehicle workshops use the wheel bearing tool!

▼ The owner of the wheel bearing tool **must** ensure that the instructions for use are available to the user and that the user has completely read and understood the instructions for use **before** using the wheel bearing tool!

▼ The owner of the wheel bearing tool **must** ensure that the user is familiar with the basic regulations on work safety and accident prevention, and that the personal protective equipment is available to him/her!

### 1.3 Intended use

The wheel bearing tool ...

▼ **may only** be used for pulling out and pressing in wheel bearing units!

▼ **may only** be used for pressing in wheel bearing units with centre bore!

▼ **may only** be used on vehicles or wheel bearing units as specified in **Chapter 2. - Product description!**

▼ **may only** be used up to a **max. load of 12 tonnes!**

▼ **may only** be operated by hand with muscle power with a manual drive or a manually operated **GEDORE Automotive** hydraulic cylinder/pump combination with pressure gauge for safe pressure control!

▼ **may only** be used with **GEDORE Automotive** genuine spare parts and accessories!

▼ **may only** be used in the way described in these operating instructions!

▲ Any other use can result in **DEATH** or **SEVERE INJURIES** !

### 1.4 Reasonably foreseeable misuse

The wheel bearing tool ...

▼ **must never** be used for pulling out and pressing in other parts or in another way than intended!

▼ **must never** be used together with an impulse or impact screwdriver!

▼ **must never** be used with a machine-operated drive or a machine-operated hydraulic cylinder/pump combination!

▼ **must never** be used with a drive other than that intended for it!

▼ **must never** be used for batch processing with numerous pressing in/out processes within a few minutes!

▼ **must never** be used with a bridged, modified, or removed safety device!

▼ **must never** be modified, converted, or used for other purposes without authorisation!

▲ Use the wheel bearing tool **always** as intended. Any other use can result in **DEATH** or in **SEVERE INJURIES**!



### 1.5 Personal protective equipment

For your safety **always** wear personal protective equipment when using the wheel bearing tool! The wheel bearing tool can bring about mechanical hazards, such as crushing, cutting and shock injuries.



Wear **EYE PROTECTION** (for example to DIN EN 166, OSHA 29 CFR 1910.133, ANSI Z87) when using the wheel bearing tool to protect yourself against flinging parts or particles!

When using the wheel bearing tool, flying parts or particles can cause **SEVERE INJURIES** to your **eyes**!



Wear **PROTECTIVE GLOVES** (for example to DIN EN 388, OSHA 29 CFR 1910.138, ANSI 105) when using the wheel bearing tool to protect yourself against sharp edges and crushing between parts!

When working with the wheel bearing tool, sharp edges and crushing between parts can cause **SEVERE INJURIES** to your **hands**!



Always wear **SAFETY SHOES** (for example to DIN EN ISO 20345, OSHA 29 CFR 1910.136, ANSI Z41) when using the wheel bearing tool to protect yourself against dropping parts!

When working with the wheel bearing tool, dropping parts can cause **SEVERE INJURIES** to your feet **and toes**!

EN

### 1.6 Labelling of the warnings

**Warnings** warn of potential **hazards**. **Always** observe these warnings to avoid **DEATH** or **INJURIES**!

For better differentiation, warnings in these operating instructions are classified as follows:	
Warning sign	Meaning
	<b>Indicates</b> a hazardous situation, which, if not avoided, could cause <b>DEATH</b> or <b>SERIOUS INJURIES</b> .
	<b>Indicates</b> a hazardous situation which, if not avoided, could cause <b>MODERATE</b> or <b>MINOR INJURIES</b> .
	<b>Indicates</b> a situation which, if not avoided, could cause damage to the tool or an object in its vicinity.
	<b>Note</b> on important information and useful tips.

### 1.7 Work environment

For your safety **only** use the wheel bearing tool in a safe working environment.

- When using the wheel bearing tool, the workplace **must** be clean and tidy.
- The workplace **must** be sufficiently large and illuminated.
- The workplace **must** be on a solid and non-skidding floor.
- The workplace **must** be safeguarded against access of unauthorised persons.
- The workplace **must** be at room temperature between -10°C and +40°C.

### 1.8 Emissions

Molybdenum disulphide paste and hydraulic oil can ES drip or escape when using the wheel bearing tool and thus pose a hazard to the environment.

- Immediately** remove leaking hydraulic oil as well as excess molybdenum disulphide paste (using oil binding agents or a cleaning cloth, for example).
- In case of skin contact with hydraulic oil, clean the affected area **immediately** with degreasing soap and water.
- Dispose of pollutants such as hydraulic oil and molybdenum disulphide paste **always in an environmentally friendly** manner.
- Safety data sheets *in accordance with Regulation (EC) No. 1907/2006*, for hydraulic oil (**Alsus Hyd HLP 32**) as well as for molybdenum disulphide paste (**MOLYKOTE® G-N PLUS PASTE**) can be found on the manufacturer's site on the Internet (**World Wide Web**) or, if required, contact **GEDORE Automotive GmbH**.

## 1.9 Basic safety instructions and warnings

### **⚠ WARNING - Failure to observe this warning may result in an accident or death.**

When using the wheel bearing tool, **always** observe the following safety and warning instructions as well as measures to avoid **DEATH** or **SERIOUS INJURY** as well as property damage due to hazards, misuse, abuse and unsafe handling!

- ✔ Read and understand these operating instructions **before using** the wheel bearing tool, and observe all safety and warning instructions for **safe use!**
- ✔ **Always** work with the wheel bearing tool in accordance with the basic regulations on work safety, accident prevention and environmental protection!
- ✔ **Always** use the wheel bearing tool as intended. **GEDORE Automotive GmbH** accepts no liability or warranty or guarantee claims for injuries and damage resulting from improper use or failure to observe the safety regulations.
- ✔ **Before each use**, check the wheel bearing tool **carefully** for damage, loose parts, or unauthorised modifications. **Never** use it if you notice any such deficiencies! Professional inspection and repair may only be carried out by specially trained personnel from **GEDORE Automotive GmbH!**
- ✔ **Only** use original spare parts and accessories from **GEDORE Automotive GmbH** for the wheel bearing tool!
- ✔ **Always** observe the vehicle-specific manufacturer's specifications when working with the wheel bearing tool!
- ✔ Secure the wheel bearing tool against falling down and flinging around, for example by holding it or by using the **GEDORE** safety retaining belt - **KL-0040-2590** or, alternatively, the retaining device **KL-0040-258 A!**
- ✔ **Never** use the wheel bearing tool with an impulse or impact wrench or any other drive than intended! Drive it **only** by hand and with muscle power; use a manual drive or a manually operated **GEDORE Automotive** hydraulic cylinder/pump combination with a pressure gauge for safe pressure control!
- ✔ **Never** use the wheel bearing tool for batch processing with numerous forcing in/out processes within a few minutes!
- ✔ **Never** use the wheel bearing tool when you are tired or under the influence of alcohol, drugs, or medication!
- ✔ **If necessary**, carry, lift, and position the SEVERE parts of the wheel bearing tool with the help of a second specialist!
- ✔ **Before using** the wheel bearing tool, make sure that **no** unauthorised persons are in the immediate environment!
- ✔ **Always** observe the **max. loading capacity** when using the wheel bearing tool, and **never** exceed it!
- ✔ **Never** stand in axial extension of the wheel bearing tool when it is under load!
- ✔ Wear your personal protective equipment such as safety goggles, protective gloves, safety shoes during work!
- ✔ Interrupt your work **immediately** if you are unsure about using the wheel bearing tool, and contact **GEDORE Automotive GmbH if necessary!**
- ✔ **Always** make sure that the wheel bearing tool is securely attached to the vehicle!
- ✔ **Never** leave the wheel bearing tool unattended in loaded condition on the vehicle!
- ✔ **Never** hit the wheel bearing tool with a hammer or other objects and **never** clamp it in a vice!
- ✔ **Always** avoid dropping, hitting or knocking the wheel bearing tool, especially when it is under load! **Always** place the tool on a clean shelf or workbench to prevent it from falling down!
- ✔ Prior to each use, check the moving parts and the spindle of the wheel bearing tool for sufficient lubrication. If necessary, lubricate them **only** with molybdenum disulphide paste (for example **GEDORE Automotive - KL-0014-0030!**)
- ✔ Interrupt your work **immediately** if you are unsure about using the wheel bearing tool, and contact **GEDORE Automotive GmbH if necessary!**
- ✔ For safety reasons, ensure that a damaged wheel bearing tool is no longer used! Professional inspection and repair may only be carried out by specially trained personnel from **GEDORE Automotive GmbH!**

## 1.10 Maintenance

Perform maintenance on the wheel bearing tool **at regular intervals** and **only** when the tool is depressurised and/or de-energised! Poor and improper maintenance can damage the wheel bearing tool, thus causing **DEATH** or **SEVERE INJURIES!**

### **Prior to each use:**

- ✔ **Prior to each use**, check the wheel bearing tool **carefully** for damage, loose parts or unauthorised modifications!
- ✔ **Prior to each use** of the wheel bearing tool, check the spindle for contamination and damage. If necessary, clean them, and subsequently lubricate them **only** with molybdenum disulphide paste! (for example, **GEDORE Automotive - KL-0014-0030**)

### **Recommended: Every 24 months:**

- ✔ Have the wheel bearing tool professionally checked **every 24 months** by authorised **GEDORE Automotive GmbH** specialists!

## 1.11 Troubleshooting

**Always** perform troubleshooting on the wheel bearing tool puller when it is depressurised/tension-free.

**Problem:** Hydraulic oil escapes from the hydraulic coupling between hydraulic cylinder and hand pump.

**Reason:** Hydraulic coupling contaminated or loose.

**Remedy:** Clean and retighten the hydraulic coupling. Top up lacking hydraulic oil (**HLP 32**) at the hand pump.

**Problem:** The hydraulic hand pump does not build up pressure or only very slowly.

**Reason:** The pressure release valve on the hydraulic hand pump is open or hydraulic oil is missing.

**Remedy:** Close the pressure release valve on the hydraulic pump completely. Top up lacking hydraulic oil (**HLP 32**) at the hydraulic hand pump.

## 1.12 Care / Storage

### **CAUTION**

Improper care and storage can damage the wheel bearing tool.

- ✔ Therefore, **never** immerse the wheel bearing tool in water, solvents, or other cleaning liquids.
- ✔ After use, clean all parts with a dry and clean cleaning cloth.
- ✔ Store the wheel bearing tool and the operating instructions at a dry and clean place.

## 1.13 Repair

### **WARNING**

Improper repair of wheel bearing tool can result in **DEATH** or **SEVERE INJURIES**.

- ✔ If damage, loose parts or unauthorised modifications have been found on the wheel bearing tool, it must no longer be used for safety reasons!
  - ✔ Repair may only be carried out by specially trained personnel from **GEDORE Automotive GmbH**!
  - ✔ **Only** use original spare parts and accessories from **GEDORE Automotive GmbH** for the wheel bearing tool!
- If necessary, contact us, the **GEDORE Automotive GmbH** for a professional inspection and repair of the wheel bearing tool.

## 1.14 Environmentally friendly disposal

Dispose of the wheel bearing tool and the packaging material in an environmentally compatible way in accordance with the legal requirements. If necessary, ask your local authorities about environmentally friendly disposal options.

## 2. PRODUCT DESCRIPTION

### 2.1 KL-0041-452 C - Wheel bearing tool, Ø 85mm

Fits with wheel bearing units without centre bore for example on rear axles with wheel bearing dia. 85mm with Toyota ProAce; Peugeot Expert, Traveller; Citroen Jumpy, Spacetourer, and many more.

Also fits with conventional wheel bearing units with centre bore and hole circle Ø 5x108, 5x112mm.

For quick and professional removal and installation of wheel bearing units directly on the vehicle.

The particular construction of the tool particularly enables the removal and installation of wheel bearing units without centre bore. Thereby the wheel bearing is directly pulled out via the wheel hub and pressed in again damage-free via the outer ring of the wheel bearing.

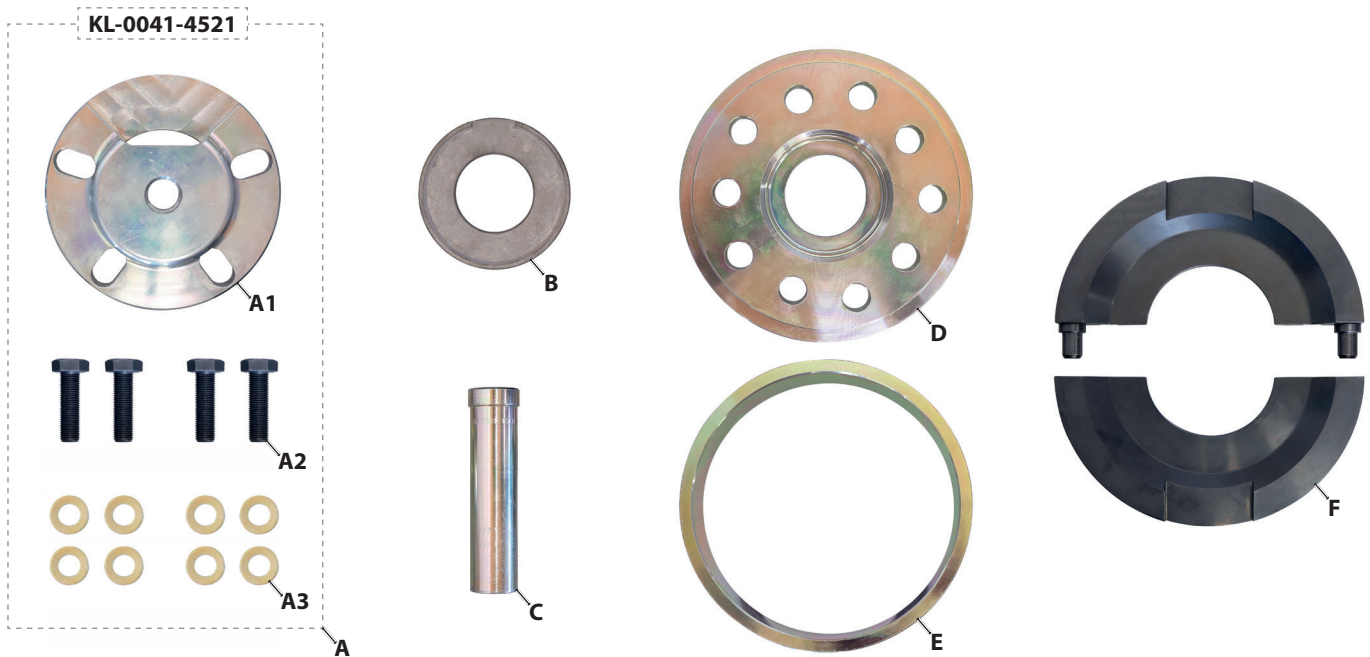

### 2.2 Scope of delivery / Overview of the single parts

① Prior to using the wheel bearing tool, check to ensure that all the parts included in the scope of delivery are available.

Item	Part no.	Description	Qty.
A	KL-0041-4521	Puller plate with screws	1
A1	KL-0041-4521-1	Puller plate	1
A2	KL-0041-4521-2	Hex screw M12x1.25 x 40mm	4
A3	KL-0066-0004	Washer M12	8
B	KL-0039-1289	Thrust ring	1
C	KL-0039-1802	Centring sleeve long	1
D	KL-0041-4608 D	Cover	1
E	KL-0041-4607	Housing	1
F	KL-0041-4500 B	Pair of clamping jaws Ø 85mm	1

### 2.3 Specifications

Maximum load capacity: ..... 12 tonnes

### 3. PREPARATION

#### 3.1 Required drive parts

##### **⚠ WARNING**

Using a machine-operated drive can cause the wheel bearing tool to slip, break and thus drop or be hurled about. This can cause **DEATH** or **SEVERE INJURIES!**

- ▣ The wheel bearing tool must **never** be used with a mechanical drive, e.g. an impulse or impact wrench or a drive other than that intended for it!
- ▣ The wheel bearing tool may **only** be driven by hand and with muscle power and a manually operated **GEDORE Automotive** hydraulic cylinder / pump combination with a pressure gauge for safe pressure control!

1. Assemble the required drive parts for the wheel bearing tool as shown in **❶**.

❶ For other drive components and accessories see the **GEDORE Automotive catalogue**.

##### ❶: Assemble the required drive parts...

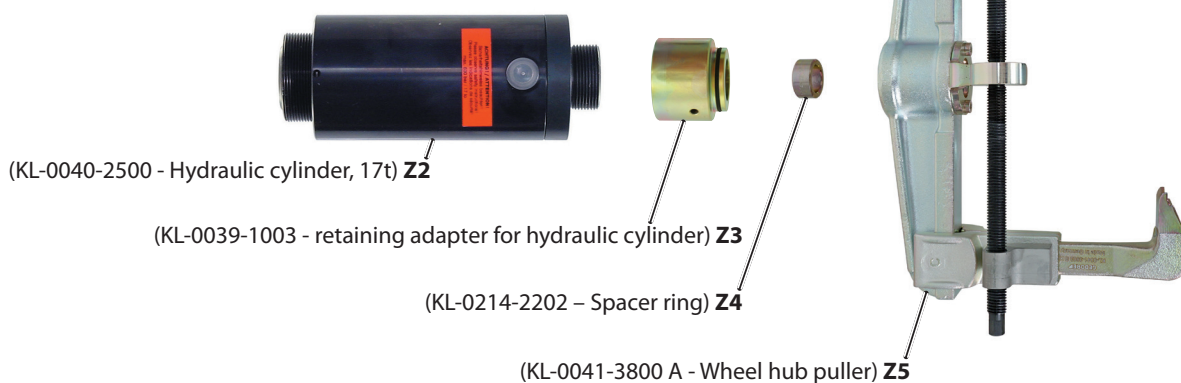
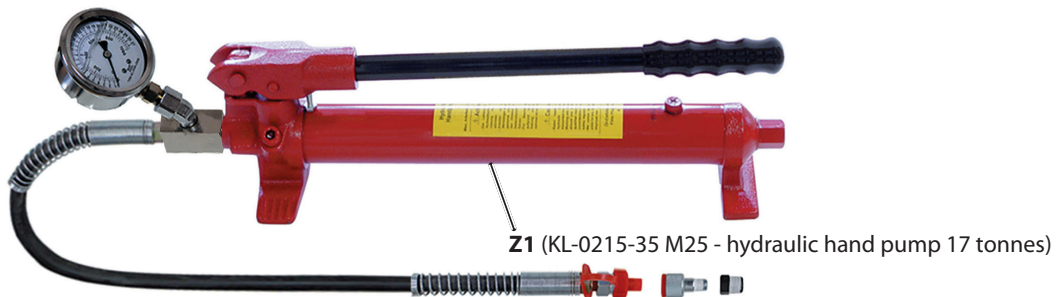



## 4. TYPICAL APPLICATION

This application example describes directly on the vehicle the extraction of a wheel bearing unit without centre bore and the pressing in of a new wheel bearing unit with centre bore.

① Pulling out with or without a centre hole is basically done in the same way. Wheel bearing units without a centre bore have been fitted to various vehicles at the factory. As a rule, a wheel bearing unit with a centre bore is supplied as a replacement.

### 4.1 Removing wheel bearing unit

#### 📷 2: Assemble wheel bearing tool accordingly...

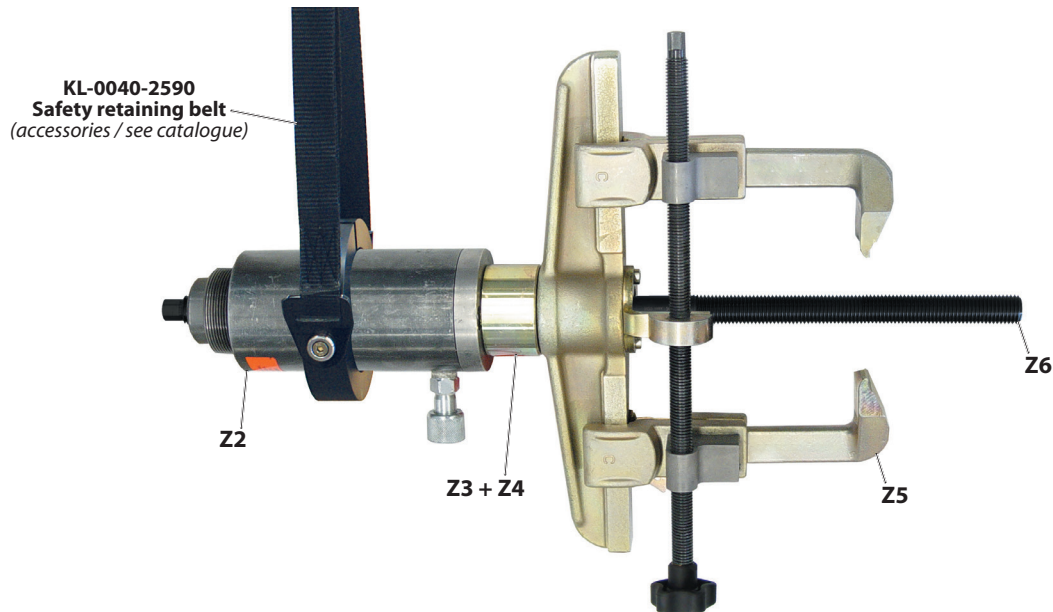

1. Assemble the wheel bearing tool accordingly, as shown.

① The safety belt **KL-0040-2590** which is available as an *accessory*, enables the wheel bearing tool to be secured to prevent it from falling down or flinging around.

#### 📷 3: Preparing the vehicle in accordance with the manufacturer specifications...

#### ⚠️ WARNING

Misuse can cause **DEATH** or **SEVERE INJURIES!**

➤ When working with the wheel bearing tool, the vehicle-specific manufacturer's specifications **must** always be observed!

2. Prepare the vehicle for the following work according to the manufacturer's specifications. For example, lift the vehicle safely, unscrew the wheel and remove the brake.

Wheel bearing unit  
(Wheel hub with wheel bearing)

Wheel bearing housing

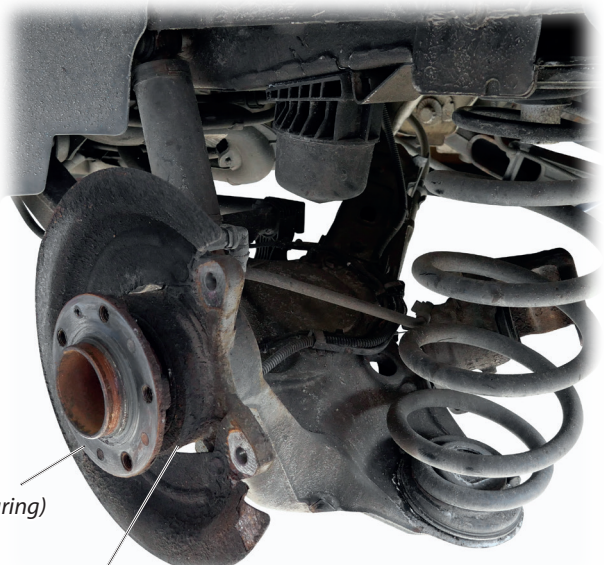



**4: Screw puller plate [A] to the wheel hub...**

**CAUTION**

The puller plate with screws [A] can be torn out and damaged when pulling out the wheel bearing unit on the wheel hub!

▼ The extraction plate [A1] **must** always be screwed to the wheel hub via all **four** screws [A2]!

3. Place the puller plate [A1] in the correct position on the wheel hub as shown and screw it in place using the screws [A2].

① Place **two** washers [A3] under each of the screws [A2] and tighten to **15Nm**.

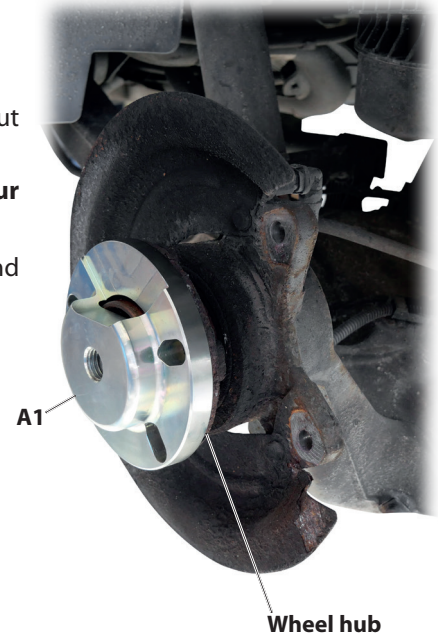
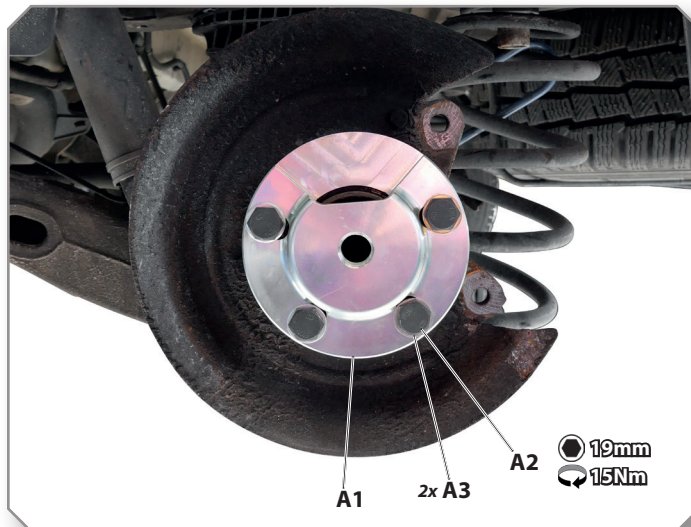

EN

**5: Screw the wheel bearing tool with the pull spindle [Z6] into the puller plate [A1]...**

**CAUTION**

The pull spindle [Z6] can be torn out of the thread of the puller plate [A1] and damaged when removing the wheel bearing unit!

▼ The puller spindle [Z6] **must** be screwed into the puller plate [A1] at least **8x turns** or **20mm deep**!

4. Attach the wheel bearing tool to the wheel bearing unit by screwing the pull spindle [Z6] into the puller plate [A1].

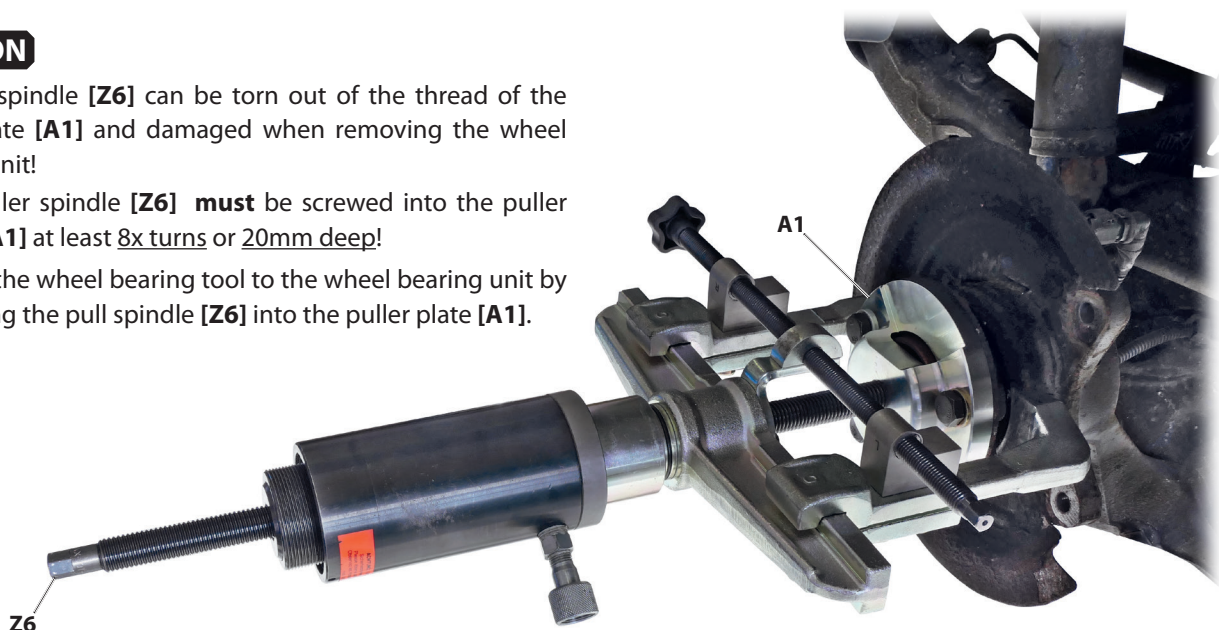

## 📷 6: Align the wheel hub puller [Z5] to the wheel bearing housing...

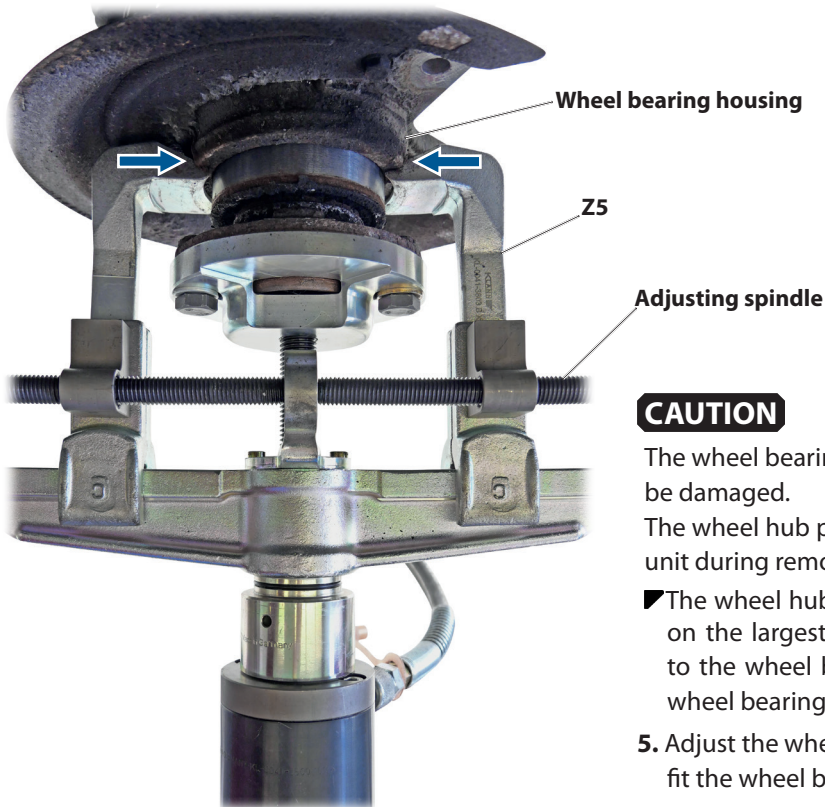

### CAUTION

The wheel bearing housing and the wheel hub puller [Z5] can be damaged.

The wheel hub puller [Z5] may collide with the wheel bearing unit during removal and be damaged.

▼ The wheel hub puller [Z5] **must** be adjusted so that it rests on the largest possible surface, evenly and at right angles to the wheel bearing housing, but cannot collide with the wheel bearing unit!

5. Adjust the wheel hub puller [Z5] via the adjusting spindle to fit the wheel bearing housing.

## 📷 7: Align puller plate [A1] to the adjusting spindle on the wheel hub puller [Z5]...

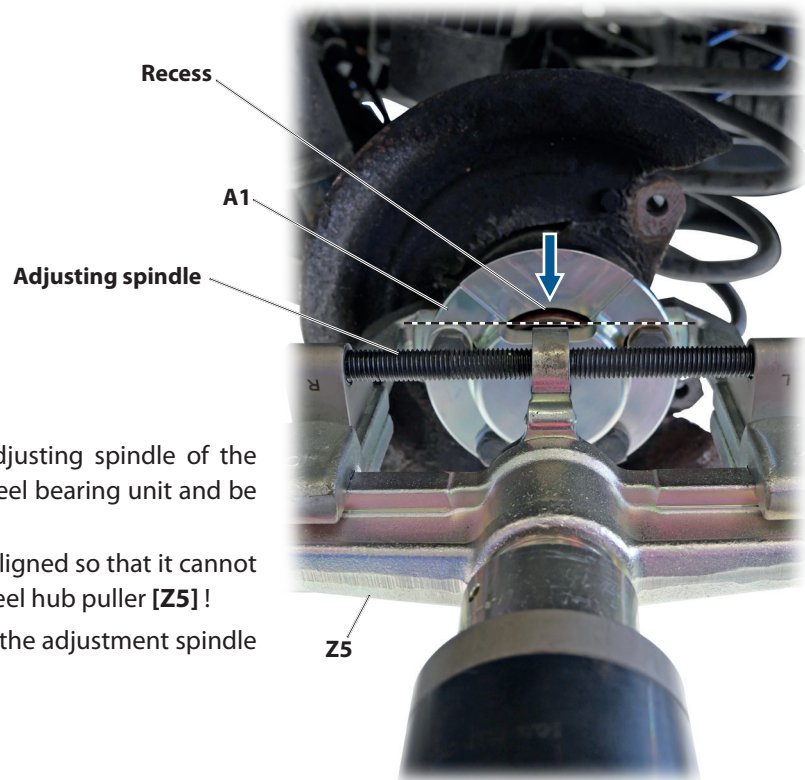

### CAUTION

The puller plate [A1] can collide with the adjusting spindle of the wheel hub puller [Z5] when removing the wheel bearing unit and be damaged.

▼ The recess of the puller plate [A1] **must** be aligned so that it cannot collide with the adjusting spindle on the wheel hub puller [Z5]!

6. Align the recess of the puller plate [A1] with the adjustment spindle on the wheel hub puller [Z5].



**8: Pull out the wheel bearing unit in a controlled manner...**

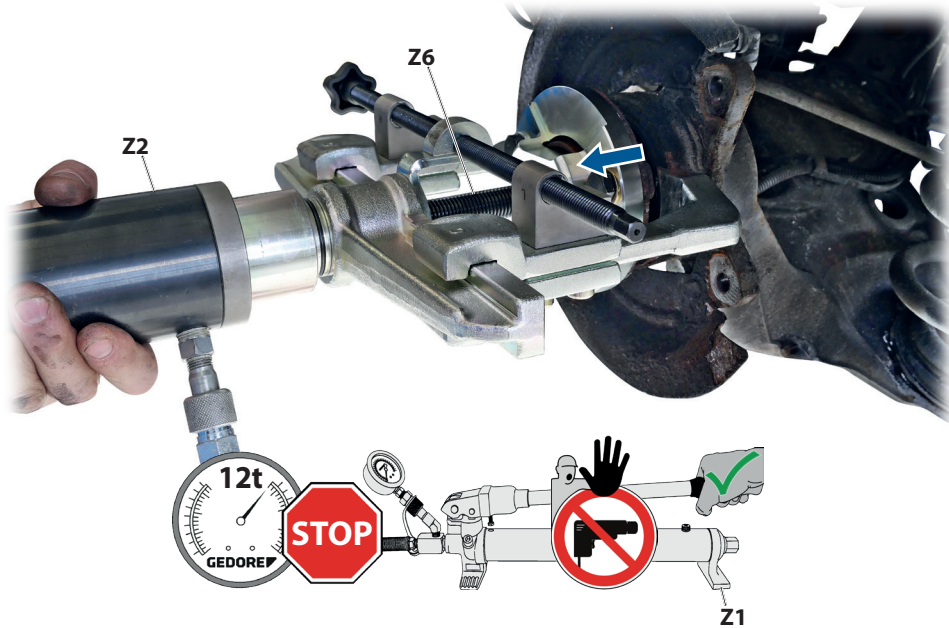

**WARNING**

The wheel bearing tool can break, fling around, and fall down when pulling out wheel bearing unit. This can cause **DEATH** or **SEVERE INJURIES!**

- ▀ The **max. load** of the wheel bearing tool of **12 tons** must **never be exceeded!**
- ▀ The pressure on the pressure gauge of the hydraulic pump **[Z1]** **must always** be observed during use!
- ▀ During use, **never** stand in axial extension of the loaded pull spindle **[Z6]**!
- ▀ The wheel bearing tool must **never** be used with a mechanical drive, e.g. an impulse or impact wrench or a drive other than that intended for it!
- ▀ The wheel bearing tool **must** be secured against flinging around and falling down, for example by holding it or via the safety retaining belt - **KL-0040-2590** or the support device - **KL-0040-258 A**

**7. Connect the hydraulic pump [Z1] with the hydraulic cylinder [Z2].**

While you are operating the hydraulic pump **[Z1]**, watch the pressure on the pressure gauge, and remove the wheel bearing unit from the steering knuckle.

- ⓘ The maximum stroke of the hydraulic cylinder **[Z2]** is 50mm! As soon as it is reached: Interrupt the forcing process, relieve the pressure at the hydraulic pump **[Z1]**, re-tighten the pull spindle **[Z6]** until it is fully applied, and continue the forcing process.

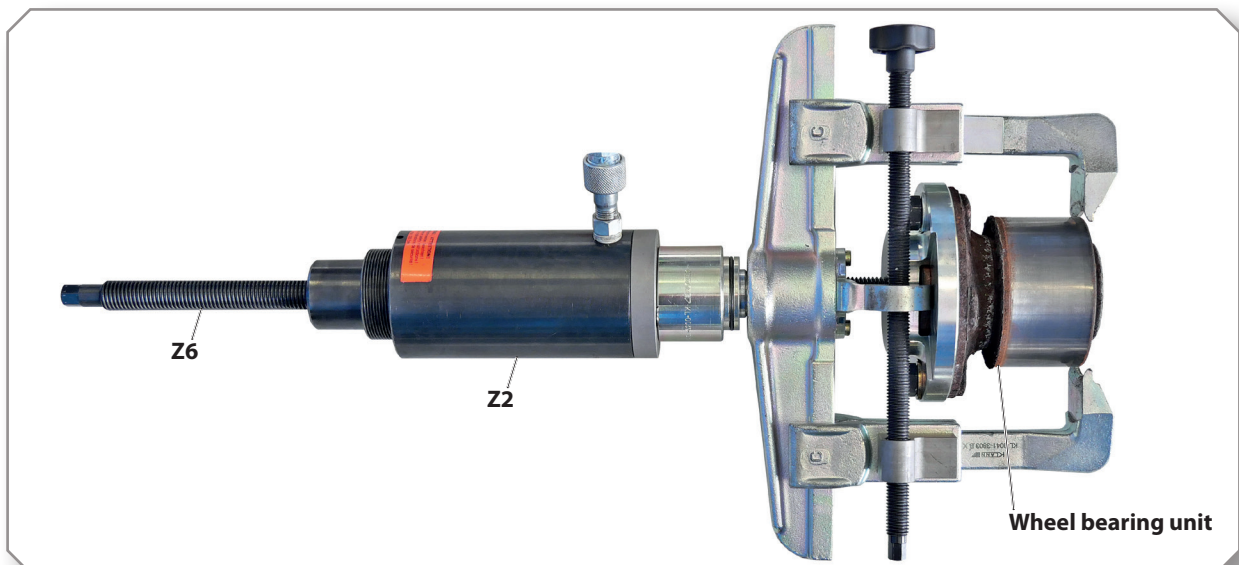

## 4.2 Pressing in the wheel bearing unit

📷 10: Insert the pair of clamping jaws [F] on the wheel bearing unit...

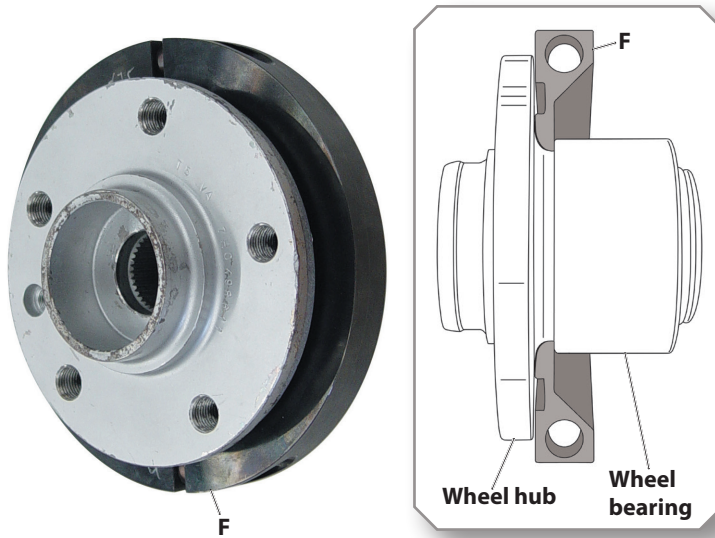

### CAUTION

The wheel bearing unit can be damaged.

▼ The pair of clamping jaws [F] **must** be aligned so that they are completely and cleanly seated between the wheel hub and the wheel bearing!

1. Insert the pair of clamping jaws [F] in the correct position on the wheel bearing unit as shown.

📷 11: Fix the lid and the housing on the wheel bearing unit...

### CAUTION

When tightening the screws [A2], the wheel bearing unit may be damaged!

▼ The **four** screws [A2] **must only be tightened lightly by hand**, they are **only** used to fix the lid [D] to the housing [E]!

2. Place the lid [D] with housing [E] in the correct position as shown on the wheel bearing unit with pair of clamping jaws [F] and fix them with the screws [A2].

① Place a washer [A3] under each of the screws [A2] and tighten **lightly by hand**.

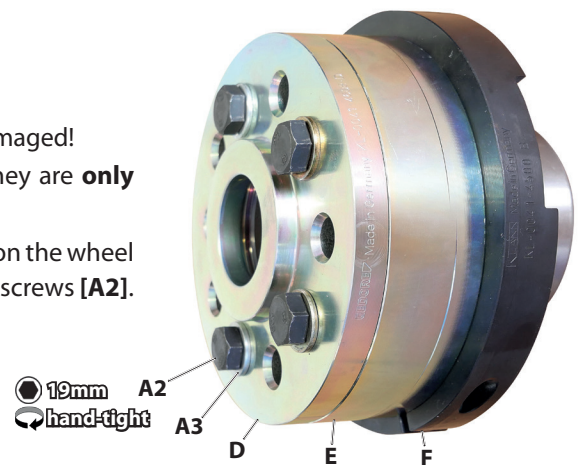

📷 12: Assemble wheel bearing tool accordingly...

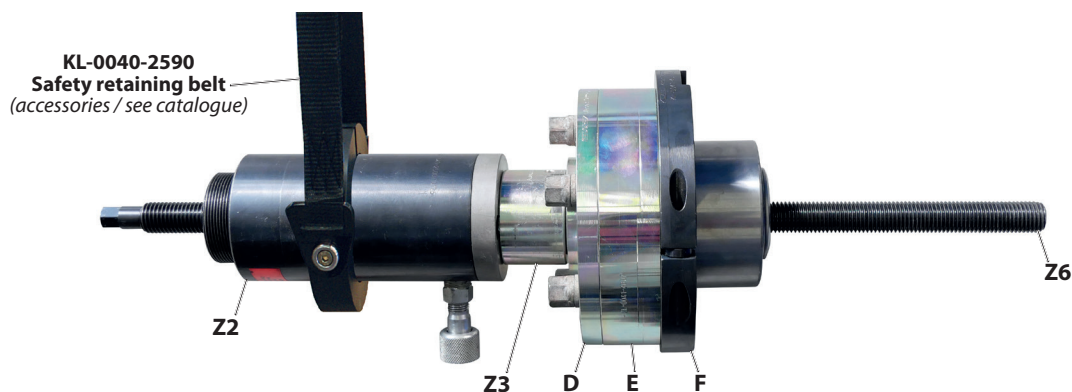

3. Assemble the wheel bearing tool accordingly, as shown.

① The safety belt **KL-0040-2590** which is available as an *accessory*, enables the wheel bearing tool to be secured to prevent it from falling down or flinging around.

**13: Insert thrust ring [B], centring sleeve [C] and mounting adapter [Z7] on the steering knuckle...**

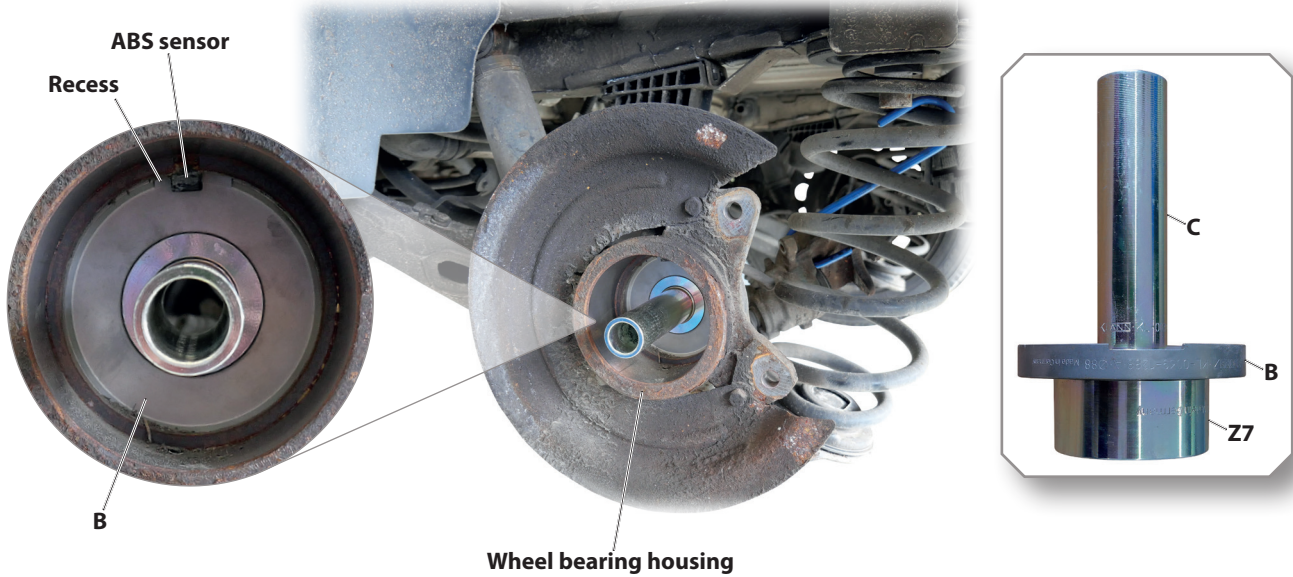

**CAUTION**

The ABS sensor can be damaged when pressing in the wheel bearing unit!

▼ The thrust ring [B] **must** be aligned so that the existing recess sits exactly over the ABS sensor!

4. Insert the thrust ring [B] together with the centring sleeve [C] and the locating adapter [Z7] in the correct position as shown, from the rear of the wheel bearing housing.

**14: Place wheel bearing tool with wheel bearing unit on wheel bearing housing....**

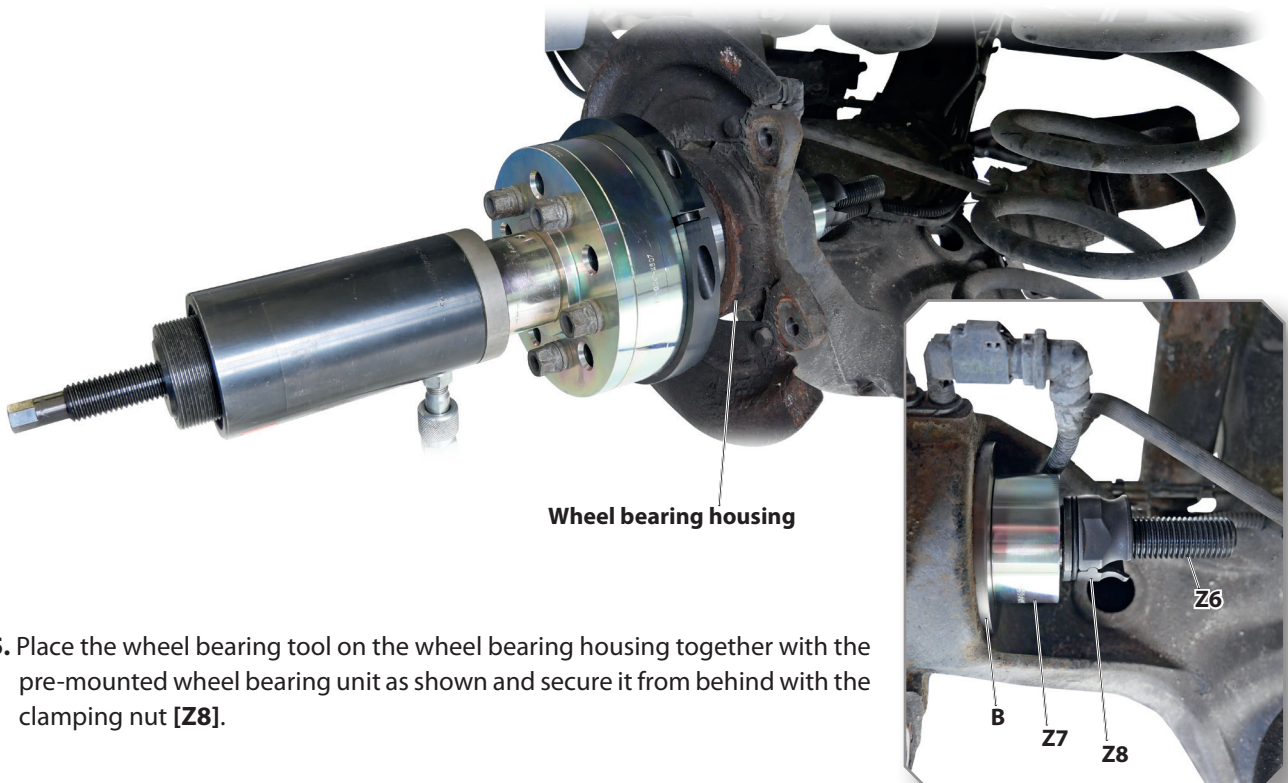

5. Place the wheel bearing tool on the wheel bearing housing together with the pre-mounted wheel bearing unit as shown and secure it from behind with the clamping nut [Z8].



**8:** Press in the wheel bearing unit in the correct position according to the manufacturer's specifications...

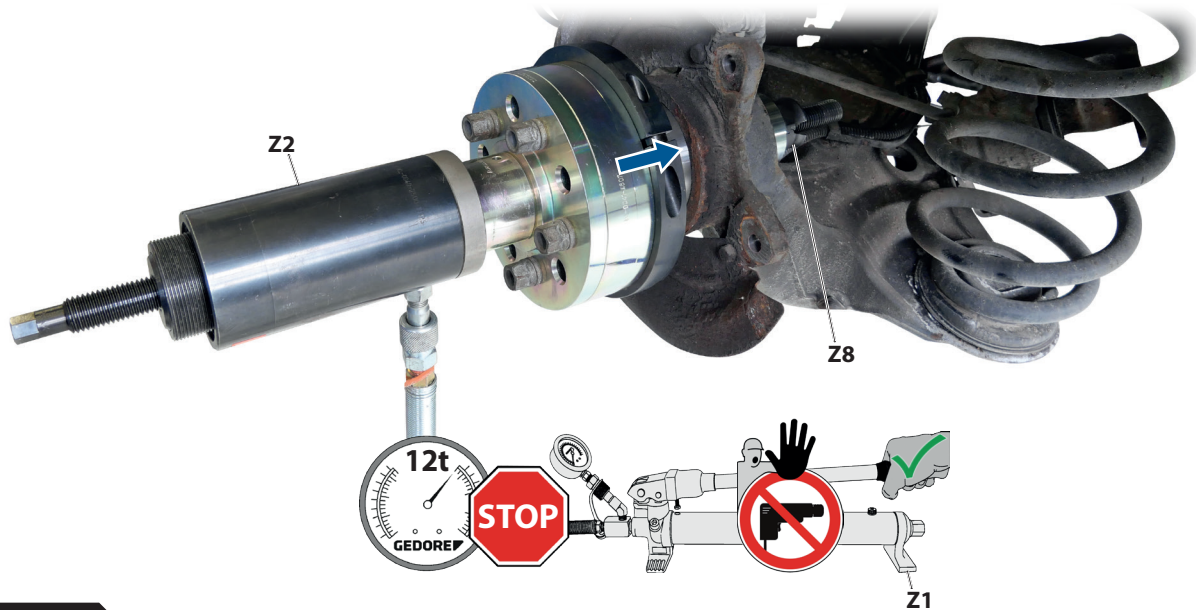

## ⚠ WARNING

The wheel bearing tool can break, fling around, and fall down when pulling out wheel bearing unit. This can cause **DEATH** or **SEVERE INJURIES!**

- ▣ The **max. load** of the wheel bearing tool of **12 tons** must **never be exceeded!**
- ▣ The pressure on the pressure gauge of the hydraulic pump [Z1] **must always** be observed during use!
- ▣ During use, **never** stand in axial extension of the loaded pull spindle [Z6]!
- ▣ The wheel bearing tool must **never** be used with a mechanical drive, e.g. an impulse or impact wrench or a drive other than that intended for it!
- ▣ The wheel bearing tool **must** be secured against flinging around and falling down, for example by holding it or via the safety retaining belt - **KL-0040-2590** or the support device - **KL-0040-258 A**

**6.** Connect the hydraulic pump [Z1] with the hydraulic cylinder [Z2].

Operate the hydraulic pump [Z1], observe the pressure on the pressure gauge and press the wheel bearing unit into the wheel bearing housing in the correct position according to the manufacturer's specifications.

ⓘ The maximum stroke of the hydraulic cylinder [Z2] is 50mm! As soon as it is reached: Interrupt the forcing process, relieve the pressure at the hydraulic pump [Z1], re-tighten the clamping nut [Z8] until it is fully applied, and continue the forcing process.



**7.** Check the correct installation position of the wheel bearing unit and reassemble the vehicle according to the manufacturer's instructions.