

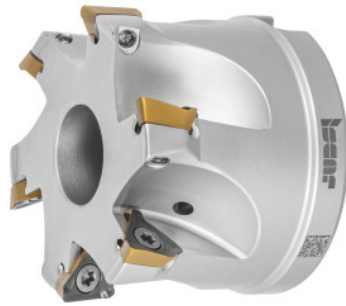

HELI3MILL shoulder mill, with bore, \varnothing DC / number of effective cutting edges Z: 63/7mm



Order data

Order number	226486 63/7
GTIN	7291075314144
Item class	19D

Description

Version:

Reliable shoulder milling system for a wide range of applications. Versions in two system sizes with cutting edge lengths in 10 and 15 mm. Optimally supported Trigon indexable inserts in the seat ensure true 90° shoulders. Ideally suited for circular interpolation milling operations and ramping.

Spare part:

Pack of indexable insert screws No. **229695 1** (TX10; 3.2 Nm).

Technical description

Overall length L_{tot}	45 mm
Cutting edge $\varnothing D_c$	63 mm
Mounting bore \varnothing	22 mm
$\varnothing D_3$	59 mm
Series	HELI3MILL

Circular interpolation milling a_p	2.9 mm
Circular interpolation milling $\varnothing D_{max}$	125 mm
Circular interpolation milling $\varnothing D_{min}$	122.4 mm
Ramping length L for α_{max}	515.62 mm
Ramping angle α_{max}	0.9 degrees
suitable indexable insert	TP..1003..
Number of cutting edges Z	7
Manufacturer's designation	HM390 FTP D063-7-22-10
Shank type	with bore
Setting angle κ	90 degrees
Milling application	Ramping
Milling application	Plunging
Milling application	Circular milling
Through-coolant	yes
Machining strategy	HPC
Type of product	End / face mill

Accessories

Set of insert screws 5 pieces Type 1	229695 1
--------------------------------------	----------