

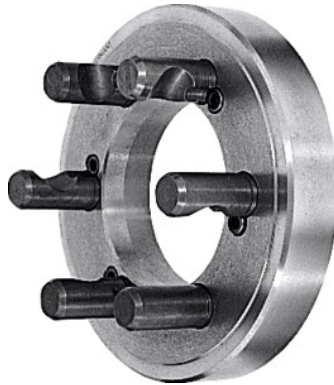

Short taper chuck flange, ASA B5.9 D1, DIN 55029, Ø d1 / taper: 315/8 mm



Order data

Order number	317700 315/8
GTIN	4019208028583
Item class	33R

Description

Version:

Finish machined on all sides.

Application:

For retrofitting to lathe chucks with recessed mount to DIN 6350 A. **Lathe chucks with incorporated short tapers are preferable due to shorter overhang.**

For spindle noses **ASA B 5.9 version D 1** (Camlock) and **DIN 55029**.

Material:

Special cast iron.

Taper Ø d₂: 139.735 mm

Thickness B: 39 mm

Number of camlock bolts: 6

Technical description

Number of camlock bolts	6
Thickness B	39 mm
Taper Ø d ₂	139.735 mm

Taper size	8
External Ø d ₁	315 mm
Type of product	Lathe chuck accessories