

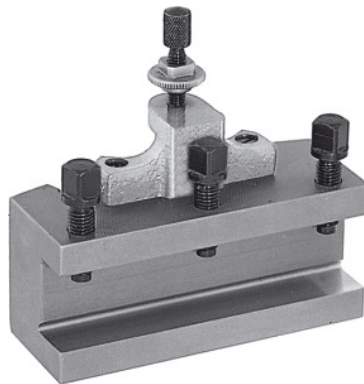

Quick-change turning toolholder, Type: B32/120



Order data

Order number	318100 B32/120
GTIN	4045197315793
Item class	36A

Description

Version:

With flat tool base. Equipped with locking height adjustment screw and 3 tool clamping screws.

Note:

When ordering spare parts No. 318110 – 318130 please state the spare part number and the size of the quick-change lathe tool post A, B C or E.

Technical description

Length	120 mm
Suitable for No. 318000	B
Height of the toolholder	32 mm
Thickness of tool support W	14 mm
Type	B32/120
Type of product	Steel toolholder

