

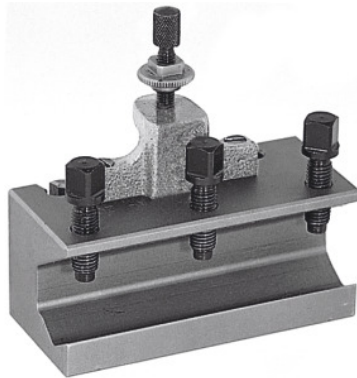

Quick-change boring bar holder, Type: C40



Order data

Order number	318200 C40
GTIN	4045197316110
Item class	36A

Description

Application:

For holding boring bars and other tools with a cylindrical shank. Equipped with locking height adjustment screw and 3 tool clamping screws.

Technical description

Suitable for No. 318000	C
Type	C40
for boring bar \varnothing	40 mm
Length	160 mm
Type of product	Steel toolholder