

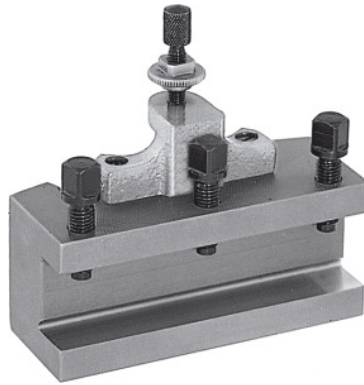

Quick-change turning toolholder, Type: B25/120



Order data

Order number	318100 B25/120
GTIN	4045197315779
Item class	36A

Description

Version:

With flat tool base. Equipped with locking height adjustment screw and 3 tool clamping screws.

Note:

When ordering spare parts No. 318110 – 318130 please state the spare part number and the size of the quick-change lathe tool post A, B C or E.

Technical description

Suitable for No. 318000	B
Length	120 mm
Type	B25/120
Thickness of tool support W	12 mm
Height of the toolholder	25 mm
Type of product	Steel toolholder

